

OPTIONAL 2" PLEATED FILTER

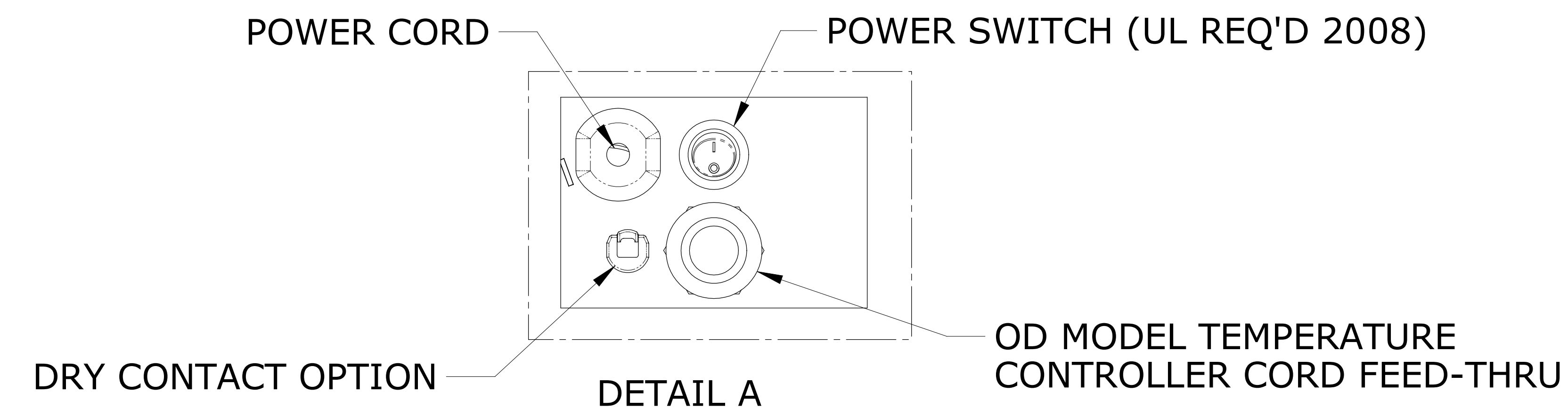

DETAIL A
ACTUAL FEATURE LOCATION MAY VARY WITHIN CUTOUT.

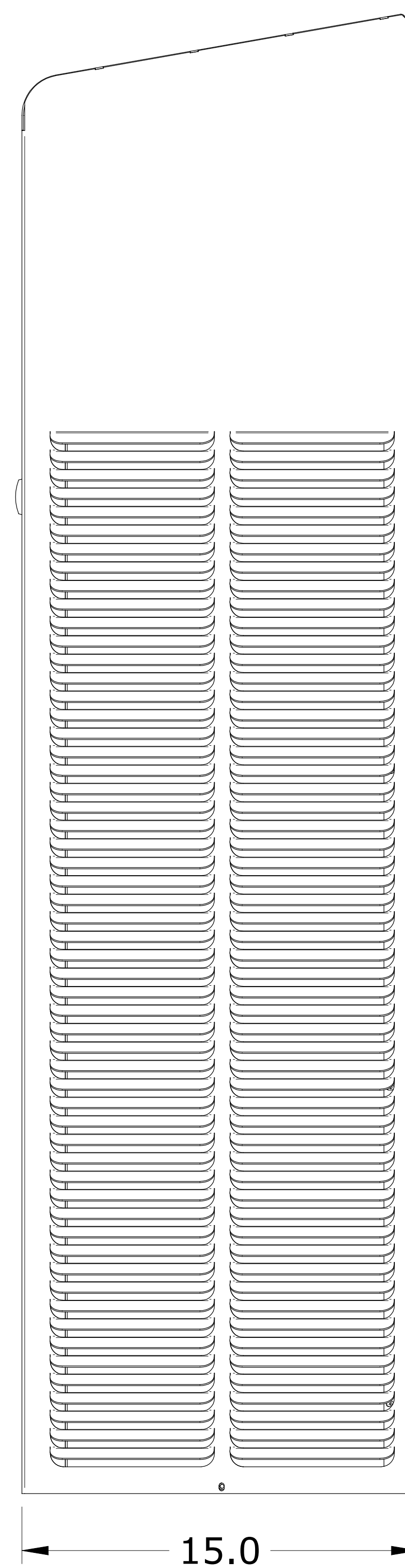
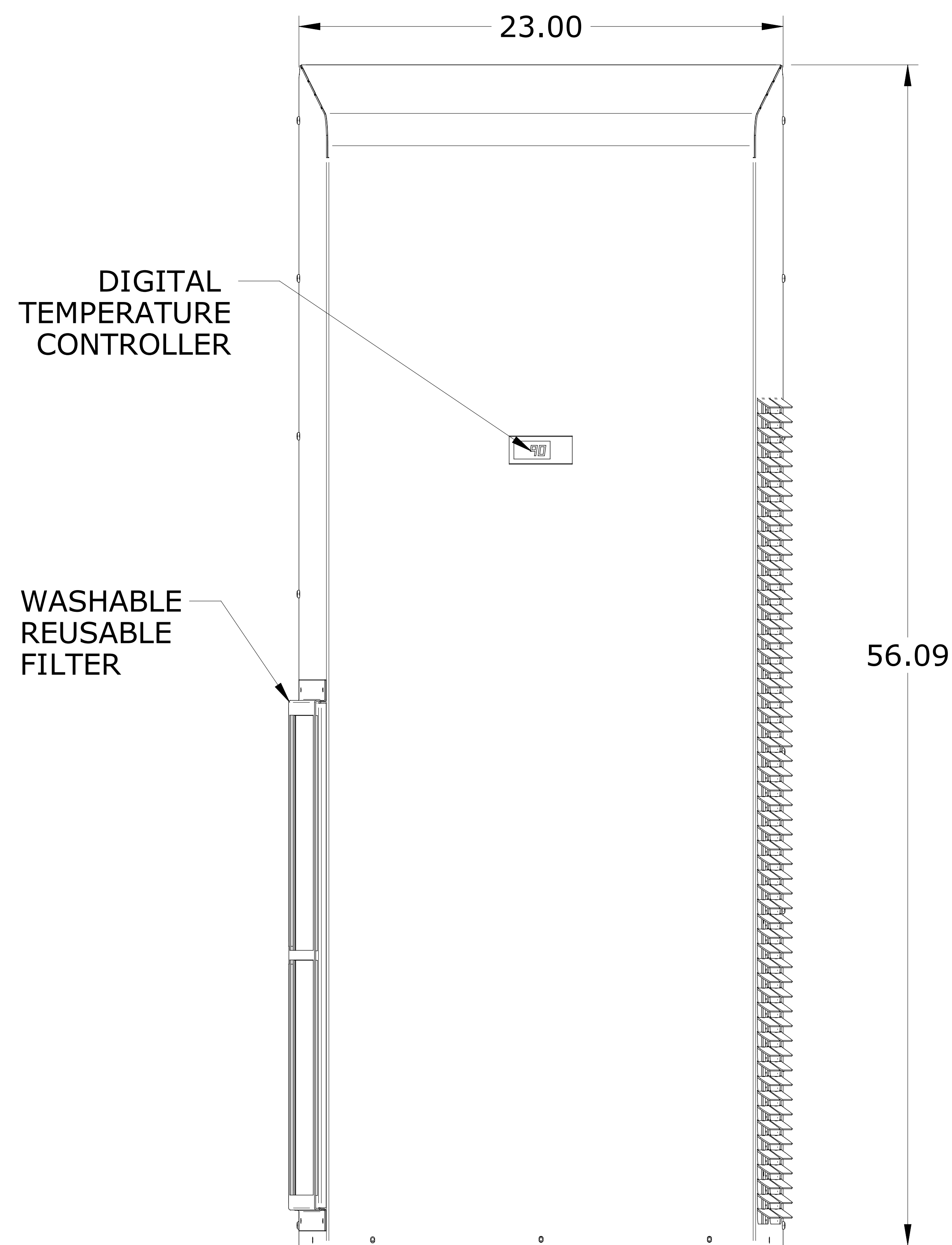

EASY MOUNT FLANGE ASSISTS PLACEMENT; UNIT INITIALLY HUNG ON RETURN AIR OPENING

RETURN AIR IN

COLD AIR SUPPLY

COLD AIR DISCHARGE TO ENCLOSURE (ANGLED DOWNWARD)

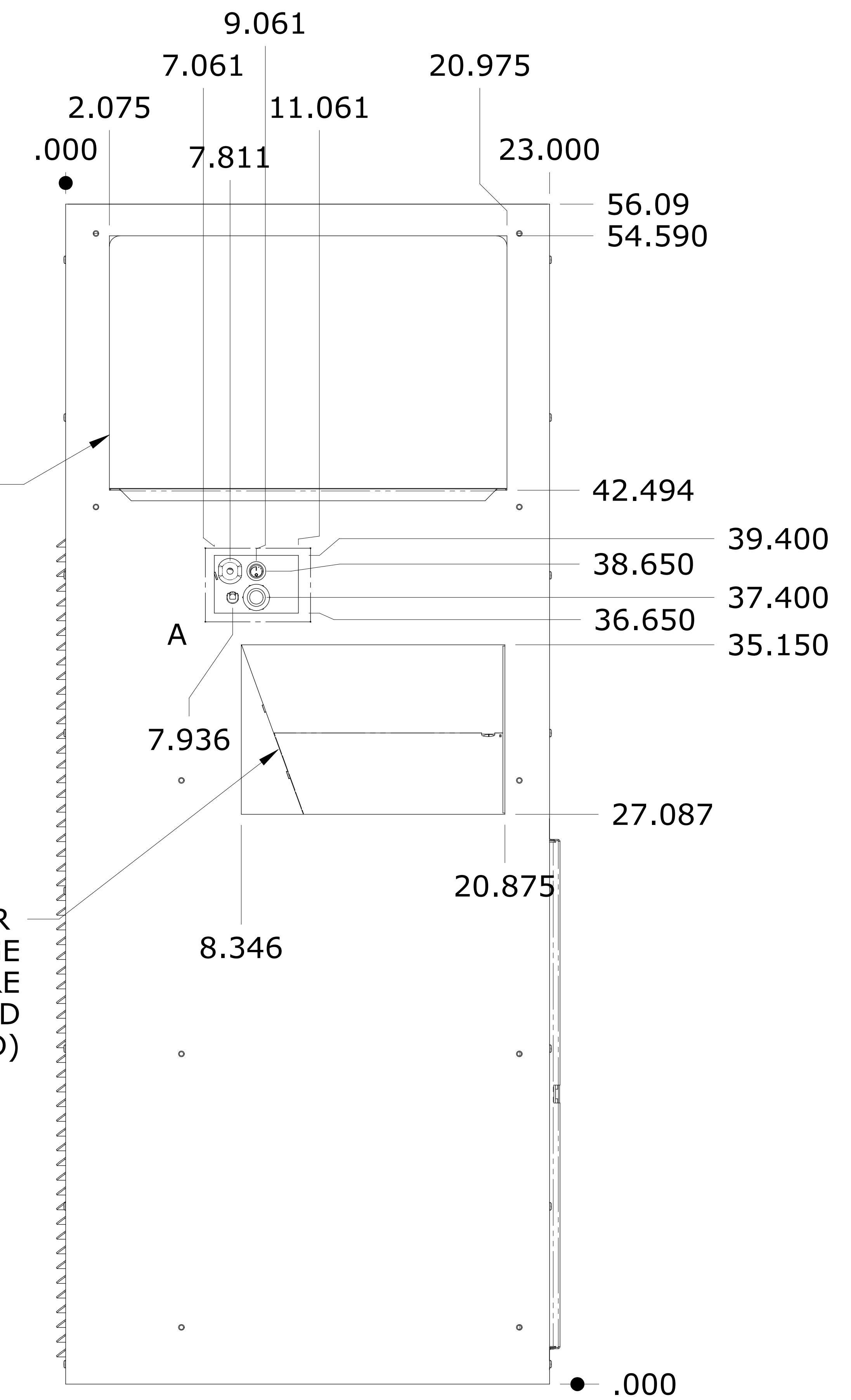

	NAME	DATE		
DRAWN	atittle	03/20/08		
CHECKED			TITLE HIGH CAPACITY HC150	
ENG APPR				
MGR APPR				
UNLESS OTHERWISE SPECIFIED DIMENSIONS ARE IN INCHES ANGLES ±1° or 1 PL ±0.5° 2 PL ±0.02 3 PL ±0.010			SIZE 170" x 110"	DWG NO HC150
			FILE NAME: isc_hc_150_drwg.dft	REV
			SCALE:	WEIGHT:
			SHEET 1 OF 1	