

Class I ($\leq 250 \text{ ft}^3$) and Zone 2 ($\leq 7.08 \text{ m}^3$)

Description

Model 3004 is a Rapid Exchange® purging system that operates on a supply of compressed instrument air or inert gas. It regulates and monitors pressure within sealed protected enclosure(s), in order to remove and prevent flammable gas or vapor accumulations. The Model 3004 consists of three major components: (1) a pneumatic manifold assembly, (2) a differential enclosure pressure indicator and (3) a stainless steel face plate with mounting flange, or a Lexan® system start up instruction nameplate. Model 3003 is offered in three distinct variations, identified as "VM" (Vertical Mount), "HM" (Horizontal Mount), both available in WPS & WPSA styles, and "CK" (Component Kit) mounting configurations. The VM configuration features a filter regulator and face plate with a flange for mounting to a vertical surface. The HM configuration features a regulator and face plate with a flange for mounting on a horizontal surface. Finally, the CK configuration is a kit of parts including the pneumatic manifold assembly, the enclosure pressure indicator and a start-up instruction nameplate. The VM and HM configurations are intended for flange or frame mounting to a solid surface on or near the protected enclosure(s), while the CK configuration is intended for frame mounting through cutouts in a panel on or near the enclosure(s). With the addition of a Model GCK gauge conversion kit, all configurations can be mounted through the surface of a protected enclosure. The CK configuration provides a seal that withstands type 4 hosedown testing. Model 3004 accomplishes the required volume exchanges and maintains a safe pressure. Pepperl+Fuchs Model EPV-3 enclosure protection vent is required for proper operation. This process reduces the hazardous (classified) area rating within protected enclosure(s), in accordance with the NEC - NFPA 70, NFPA 496, ISA 12.4 and IEC 600 79-15 EN 50021.

Operation

In accordance with system instructions, start-up requires air supply to be engaged and enclosure power to be deenergized. The enclosure protection vent must be tested and enclosure(s) must be sealed. After transferring the valve key, locked into the pneumatic manifold's Rapid Exchange® control valve stem, the enclosure pressure control valve is used to set a safe reading on the enclosure pressure indicator. When safe pressure is stable, the valve key is transferred and locked into the Rapid Exchange® control valve stem and the Rapid Exchange® control valve is then fully engaged. Upon completion of the Rapid Exchange® cycle, (five minutes minimum) the Rapid Exchange® control valve is disengaged to return to a safe enclosure pressure. Power can then be energized to the protected enclosure(s). Loss of safe pressure requires immediate attention, unless power to the protected enclosure(s) is deenergized. WPS and WPSA style systems include an explosion proof differential pressure switch with form "C" contacts for audible or visual alarm systems.

Rapid Exchange® is a Registered Trademark of Pepperl+Fuchs, Inc.

Model 3004



Model 3004-LPS-CI-YZ-VML
Vertical Mount Configuration

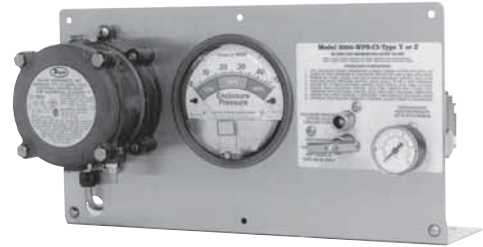

Model 3004-WPS-CI-YZ-HMT
Horizontal Mount Configuration



Model 3004-LPS-CI-YZ-CK
Component Kit Configuration



Standard Model Applications

Model Number:	3004	Model Number:	3004
Designation:	Type Y System Rapid Exchange® Purging	Designation:	Type Z and Ex [nP] System Rapid Exchange® Purging
Enclosure Volume:	250 ft ³ (7.08m ³) max.	Enclosure Volume:	250 ft ³ (7.08m ³) max.
	LPS Style		LPS Style
UL & FM Certified:	Cl. I, Div. 1, Group A-D	UL & FM Certified:	Cl. I, Div. 2, Group A-D
Rating Reduction:	Div. 1 to Div. 2	ATEX 'nP' Certified:	Zone 2, Group IIC
	WPS Style	Rating Reduction:	Div. 2 to Nonhazardous Zone 2 to Nonhazardous
UL & FM Certified:	Cl. I, Div. 1, Group C-D		WPS Style
Rating Reduction:	Div. 1 to Div. 2	UL & FM Certified:	Cl. I, Div. 2, Group C-D
	WPSA Style	Rating Reduction:	Div. 2 to Nonhazardous
UL & FM Certified:	Cl. I, Div. 1, Group A-D		WPSA Style
Rating Reduction:	Div. 1 to Div. 2	UL & FM Certified:	Cl. I, Div. 2, Group A-D
		ATEX 'nP' Certified:	Zone 2, Group IIB+H ₂
		Rating Reduction:	Div. 2 to Nonhazardous Zone 2 to Nonhazardous
			Ex II 3G EEx [nP] II

Protected under U.S. Patent #5,101,710

Model 3004 VM Configuration - The Vertical Mount System

LPS (Less Pressure Switch)

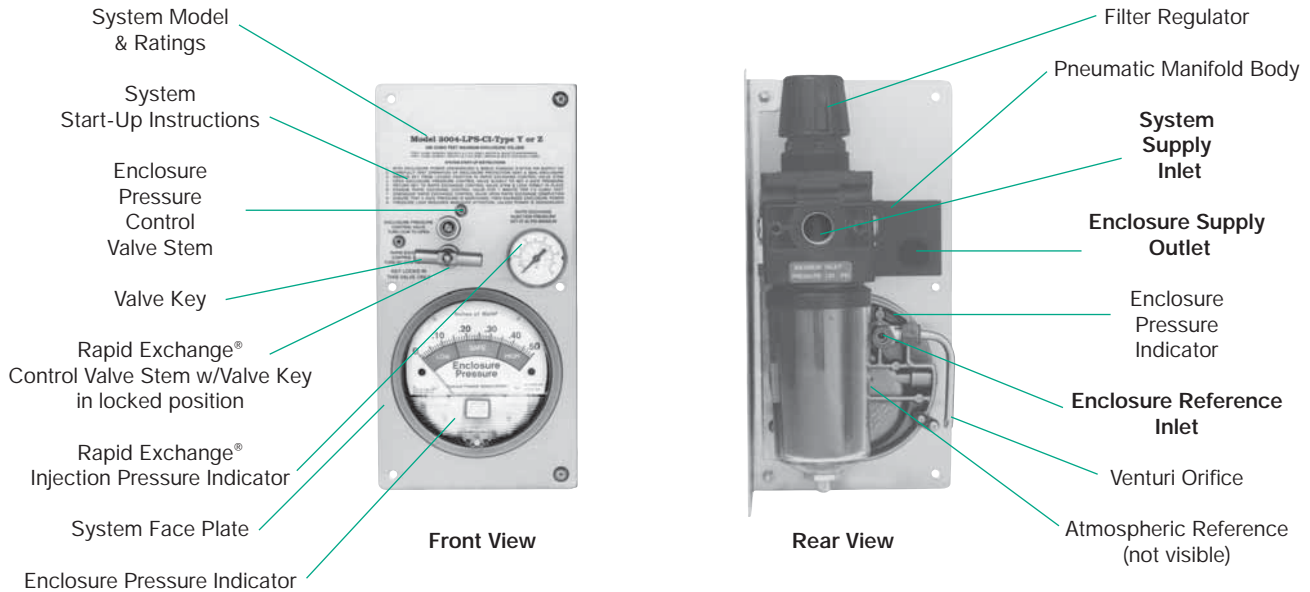

Important Notes

- 1) The VM configuration is supplied with a mounting flange for right angle-attachment to a vertical surface external to the protected enclosure.
- 2) The VM configuration can also be frame mounted external to the protected enclosure through a 5" (127mm) W x 10.75" (273mm) H cutout in a suitable mounting surface.
- 3) Model GCK gauge conversion kit is required to panel mount the VM configuration through a 5" (127mm) W x 10.75" (273mm) H cutout in the protected enclosure surface.

WPS / WPSA (With Pressure Switch)

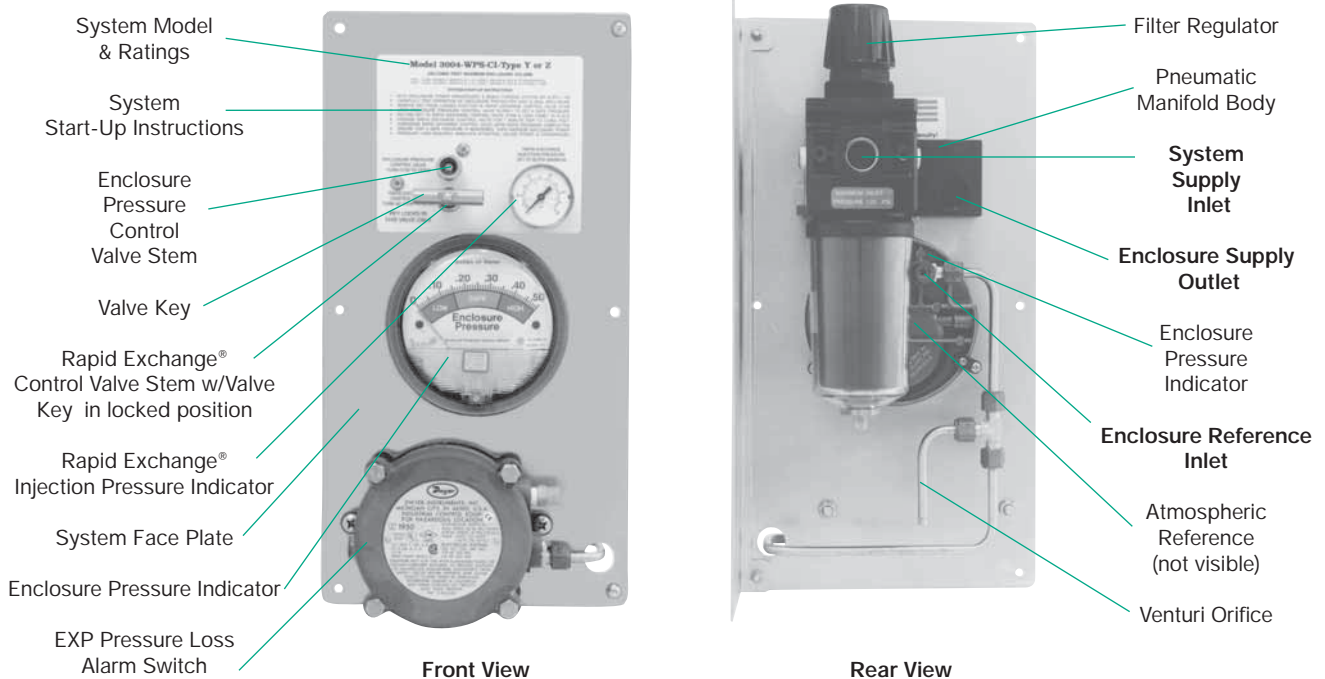

CONNECTION POINTS SHOWN ABOVE IN BOLD TEXT ON SYSTEM DIAGRAM

Model 3004 HM Configuration - The Horizontal Mount System

LPS (Less Pressure Switch)

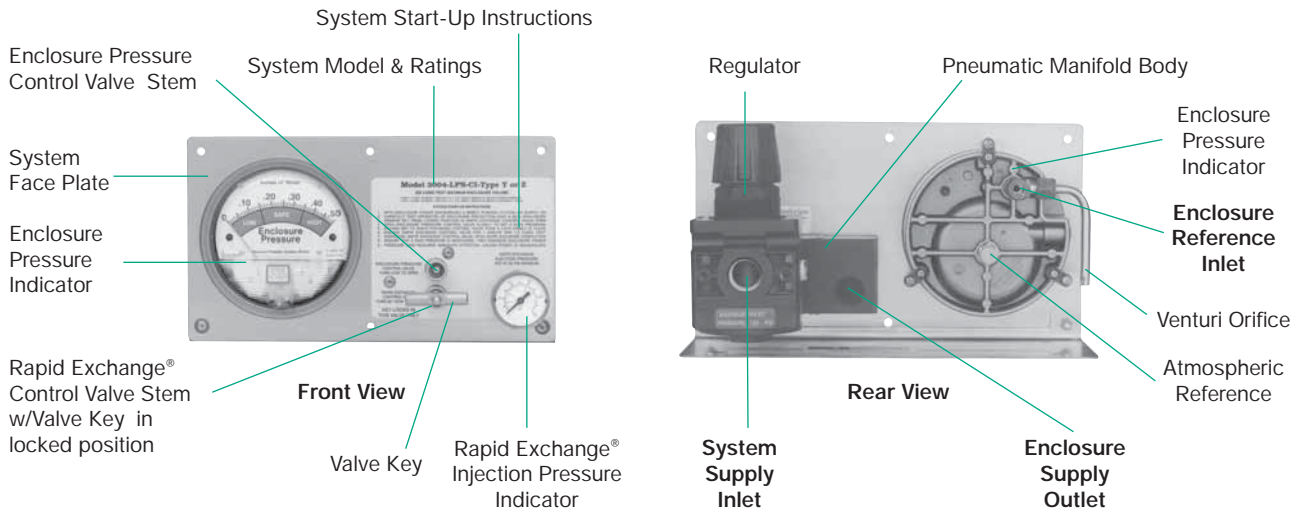

3000
SERIES

Type Y, Z & Ex [nP]

Important Notes

- 1) The HM configuration is supplied with a mounting flange for right-angled attachment to a horizontal surface external to the protected enclosure.
- 2) The HM configuration can also be frame mounted external to the protected enclosure through a 10.25" (260mm) W x 5.5" (140mm) H cutout in a suitable mounting surface.
- 3) Model GCK gauge conversion kit is required to panel mount the HM configuration through a 10.25" (260mm) W x 5.5" (140mm) H cutout in the protected enclosure surface.
- 4) See page 44 for Model GCK kit description and conversion procedure.

WPS / WPSA (With Pressure Switch)

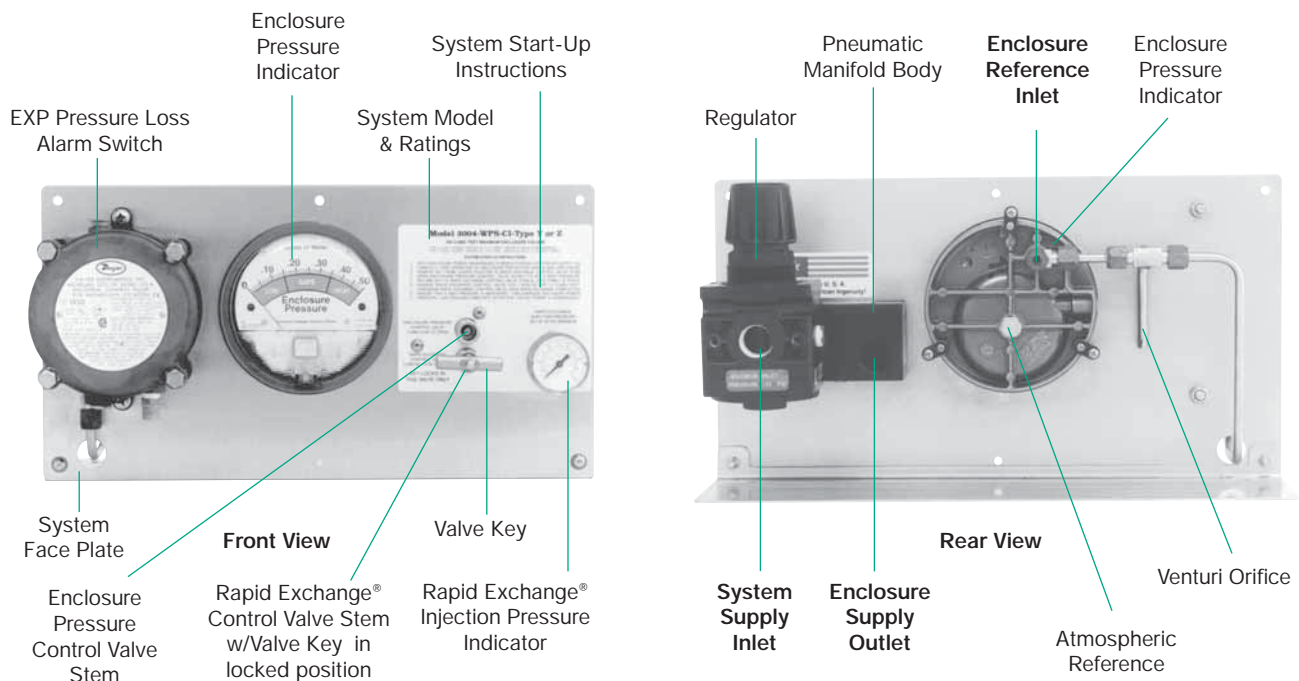

CONNECTION POINTS SHOWN ABOVE IN BOLD TEXT ON SYSTEM DIAGRAM

Type Y, Z & Ex [nP]

Model 3004 CK Configuration - The Component Kit System

Part #1
Enclosure Pressure Indicator



Front View

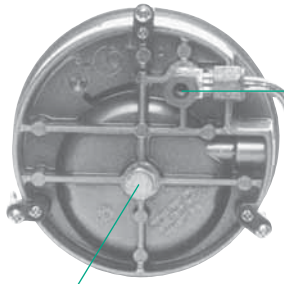

Rear View

Atmospheric Reference

Venturi Orifice

Part #2
Pneumatic Manifold Assembly

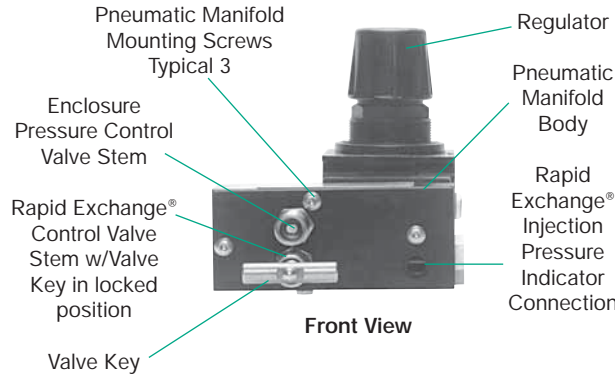

Front View

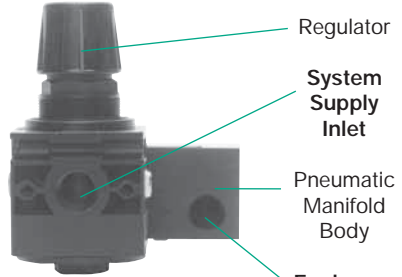

Rear View

Part #3
Rapid Exchange® Injection Pressure Indicator



Front View



Side View



Part #4
Start Up Instruction Nameplate

CONNECTION POINTS SHOWN ABOVE IN BOLD TEXT ON SYSTEM DIAGRAM

Important Notes

- 1) The CK Configuration is four discrete parts suitable for mounting through a set of cutouts in a vertical surface external to the protected enclosure.
- 2) A Model GCK gauge conversion kit is required to panel mount the CK configuration through a set of cutouts in the protected enclosure surface.
- 3) See page 44 for Model GCK kit description and conversion procedure.

CK Configuration System & Optional Remote Cube Filter Dimensions in Inches (mm)

Pneumatic Manifold

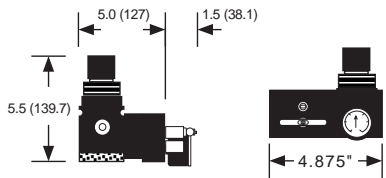

Side View

Front View

Enclosure Pressure Gauge

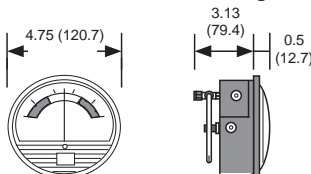

Panel Cutout
4.5 (114.3) Ø

Front View

Side View

Side View Model RCF-8

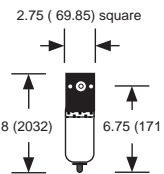

Model RCF-8
Panel Cutout Pattern

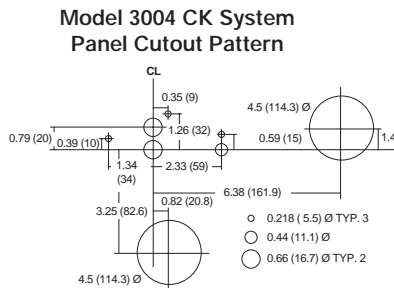

Helpful Hint

Note: Two optional Enclosure Pressure Gauge positions are shown on the Model 3004 CK System Panel Cutout Pattern to the left. The optional positions center gauge to the right or bottom side of System Nameplate.

Cut only one 4.5" (114.3mm) Ø hole in panel.

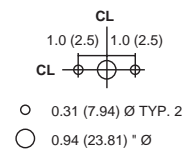

Model 3004 WPS VM Configuration & Flange Dimensions in Inches (mm)

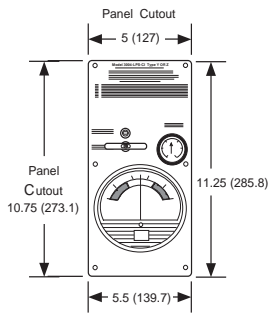

VM Configuration
Front View

LPS (Less Pressure Switch)

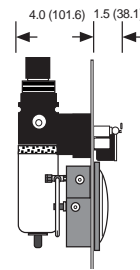

VM Configuration
Side View

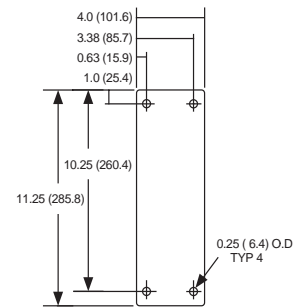

Vertical Mount Flange
Front View

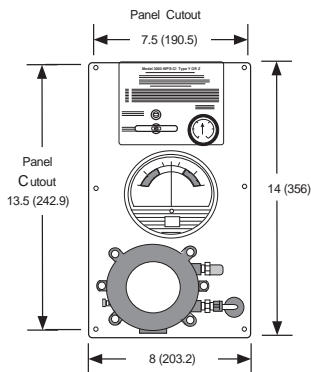

WPS/WPSA VM Configuration
Front View

WPS/WPSA (With Pressure Switch)

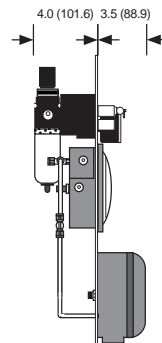

WPS/WPSA VM Configuration
Side View

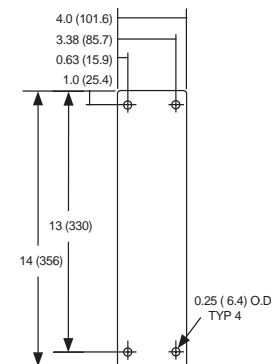

WPS/WPSA Vertical Mount Flange
Front View

Model 3004 HM Configuration & Flange Dimensions in Inches (mm)

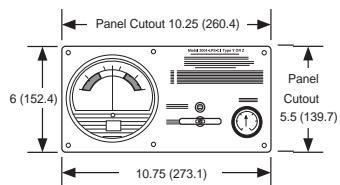

LPS HM Configuration
Front View

LPS (Less Pressure Switch)

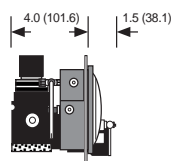

LPS HM Configuration
Side View

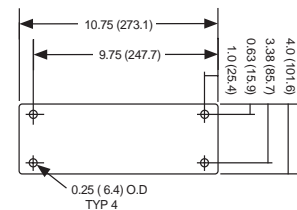

LPS Horizontal Mount Flange
Front View

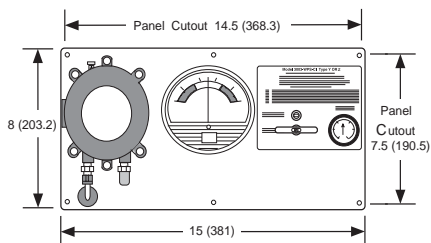

WPS/WPSA HM Configuration
Front View

WPS/WPSA (With Pressure Switch)

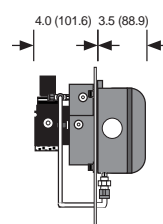

WPS/WPSA HM Configuration
Side View

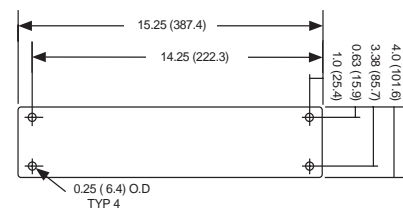

WPS/WPSA Horizontal Mount
Flange Front View

Type Y, Z & Ex [nP]

Typical Model 3004 System Installation Details

External to the Protected Enclosure

Flange Mount HM Configuration with Model SMK-1 Fastener Kit

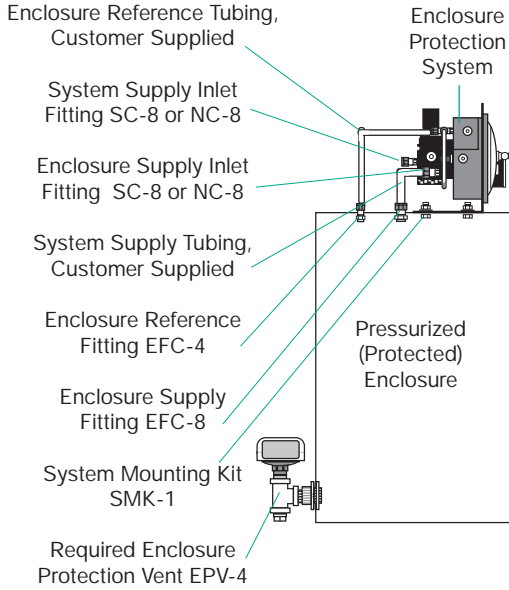

Internal to the Protected Enclosure

Panel Mount CK Configuration with Model RCF-8 Remote Cube Filter & Model GCK Gauge Conversion Kit

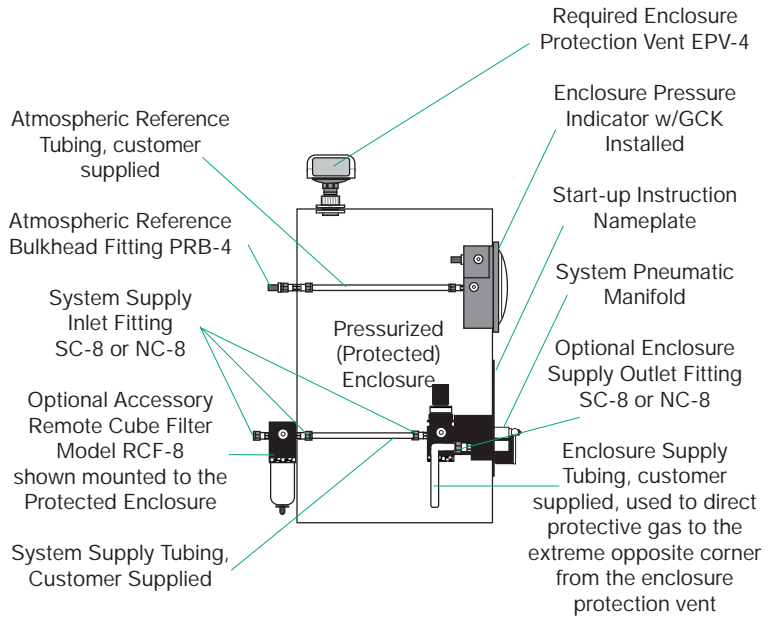

Standard and Panel Mount Pneumatic Installation Diagram

See panel mounting conversion procedure on page 44

Standard Pneumatic Installation Diagram

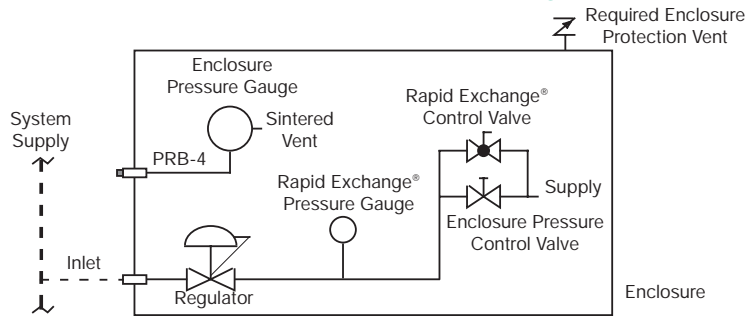

Panel Mount Installation Diagram

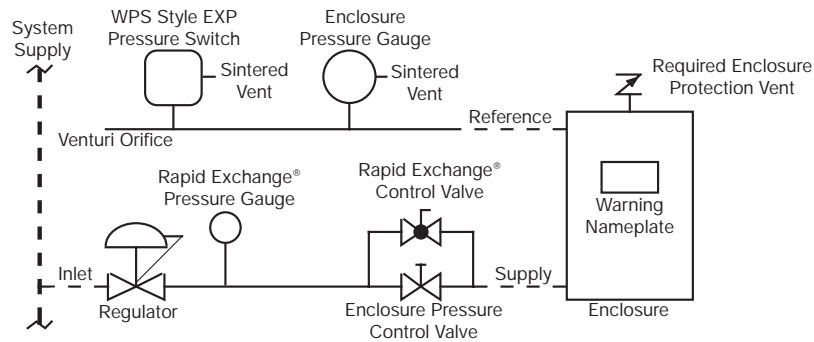

Protected under U.S. Patent #5,101,710

VM Configuration Mounting Options



Model 3004-LPS-CI-YZ-VML
Flange Mounted to
Flat Vertical Surface with
Model SMK-1 Fastener Kit

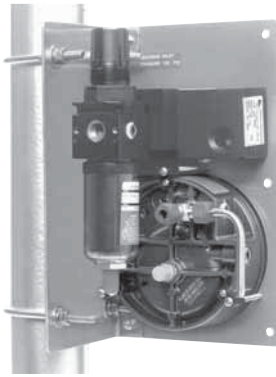

Model 3004-LPS-CI-YZ-VML
Flange Mounted to
Vertical 2" Pipe Stand with
Model PMK-1 Fastener Kit

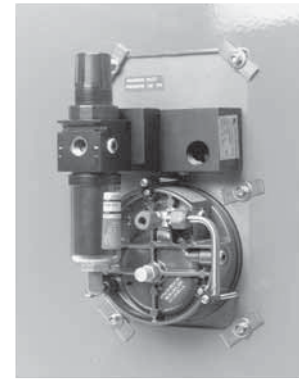

Model 3004-LPS-CI-YZ-VM
Frame or Panel* Mounted
Through Cutout in Suitable Surface
with Model SMK-6m Fastener Kit

3000
SERIES

Type Y, Z & Ex [nP]

HM Configuration Mounting Options

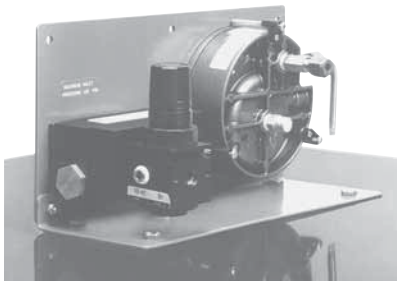

Model 3004-LPS-CI-YZ-HMT
Flange Mounted to
Flat Horizontal Surface with
Model SMK-1 Fastener Kit

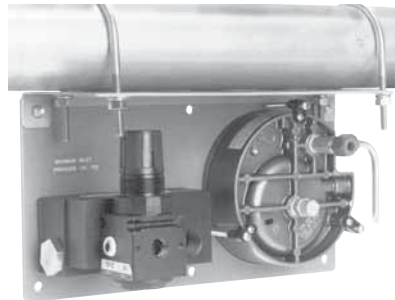

Model 3004-LPS-CI-YZ-HMB
Flange Mounted to
Horizontal 2" Pipe Stand with
Model PMK-1 Fastener Kit

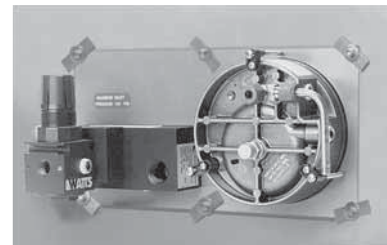

Model 3004-LPS-CI-YZ-HM
Frame or Panel* Mounted
Through Cutout in Suitable Surface
with Model SMK-6m Fastener Kit

CK Configuration Mounting Options

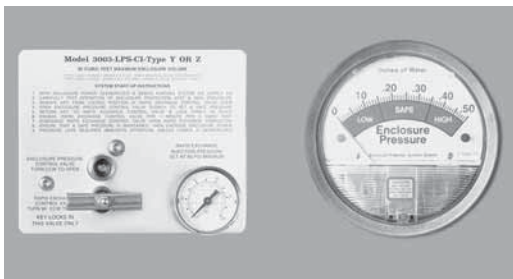

Front View

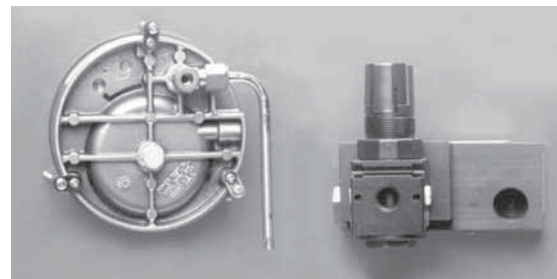

Rear View

Model 3004-LPS-CI-YZ-CK
Rear View of Frame or Panel* Mount
Through Cutout in Suitable Surface with supplied fasteners

* PANEL MOUNTED SYSTEMS REQUIRE A PEPPERL+FUCHS MODEL GCK FOR PROPER OPERATION - SEE PAGE 44

Protected under U.S. Patent #5,101,710

Type Y, Z & Ex [nP]

Model 3004 Panel Mount Conversion

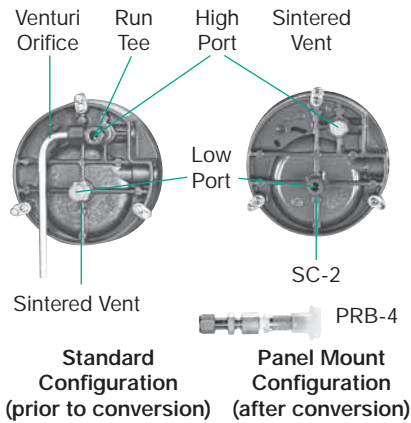

1. Secure one Model GCK Conversion Kit, kit includes a PRB-4 & SC-2 Fitting & Enclosure Pressure Gauge gasket.
2. Remove venturi orifice and run tee from the high port of the gauge and discard.
3. Remove sintered vent from low port.
4. Reinstall sintered vent into high port.
5. Install Model SC-2 fitting into low port.
6. Install Gauge gasket between gauge & mounting surface.
7. Install Model PRB-4 fitting through enclosure surface (vent end out) and connect tubing (customer supplied) between SC-2 & PRB-4.

System Specifications

System Dimensions:	See pages 40-41
Shipping Weight:	LPS-12 lb (5.4 kg) WPS-17 lb (7.7 kg)
Temp. Range:	-20°F to +120°F (-29°C to +49°C)
Supply Pressure Range:	80 - 120 psi (5.5 - 8.3 bar)
Capacity & Filtration:	8.5 oz @ 40 Micron
Supply Requirements:	clean air or inert gas
Safe Press. Setpoint:	0.25" (6.35mm)
Safe Press. Flow Rate:	* 0.1 - 3.5 SCFH (2.8 - 99 l/hr)
Exchange Pressure:	* 3" - 5" (76.2mm - 127mm)
Exchange Flow Rate:	** 30 SCFM /1800 SCFH (850 l/m / 50976 l/hr)
Exchange Time:	
4 Volume Exchange Rate:	1 min / 7.5 ft ³ (212.4 l/m)
5 Volume Exchange Rate:	1 min / 6.0 ft ³ (169.9 l/m)
System Supply Port:	1/2" FPT
Enclosure Supply Port:	1/2" FPT
Enclosure Reference Fitting:	1/4" Tube
Switch Setting (WPS & WPSA Only):	0.15" ± 0.02" (3.81mm ± 0.51mm)
Switch Conduit Port Size:	1/2" FPT
Switch Contact Ratings:	
WPS Style:	120 VAC, 15 A
WPSA Style:	*** 120 VAC, 10 A, 28 - 125 VDC

Material Specifications

Regulator Body:	Zinc w/Enamel Finish
Regulator Handle & Bowl*:	Polycarbonate
Enclosure Pressure Gauge:	Alum. w / Enamel Finish
Rapid Exchange® Gauge:	Poly & Nickel Plated
Tube Fitting:	316 SS Forged Body
Tubing:	316 SS 1/4" .035 Welded
Fastener Hardware:	Alum. & Stainless Steel
System Face Plate:	316 14 Ga #3 Brush SS
System Mounting Flange:	316 SS Tumble Finish
Manifold Body:	Anodized Aluminum
Manifold Valves:	316 Stainless Steel
Mfr. ID Nameplate:	Silkscreen Lexan®
Enclosure Warning Nameplate:	Silk screened SS
EXP Pressure Switch Body:	Anodized Cast Aluminum

* Refers to filter bowl supplied with VM mounting configuration.
Lexan® is a registered trademark of the General Electric Company

Model Number Designations

3004 - LPS - CI - YZ - VM - ##	
Series Model Number	3004
System Style	LPS - less pressure switch WPS - with pressure switch WPSA - with pressure switch
Area Classification	CI - Class I Area
System Type	YZ - Div. 1 to Div. 2 Div. 2 / Zone 2 to Nonhazardous
Mounting Configuration	VML - vertical mount left left of enclosure VMR - vertical mount right right of enclosure HMT - horizontal mount top top of enclosure HMB - horizontal mount bottom bottom of enclosure CK - Component Kit - LPS style only
## - See Accessories Page 117 for additional factory installed accessories	
† Does not have ATEX certification	

Model 3004 System Accessories (See accessories page for complete details)

CONNECTION FITTINGS	
NC-8	1/2" T x 1/2" P Ninety Connector
SC-8	1/2" T x 1/2" P Straight Connector
EFC-4	1/4" Flush Connector
EBC-4	1/4" Bulkhead Connector
EFC-8	1/2" Flush Connector
EBC-8	1/2" Bulkhead Connector
EPC-14	1 1/2" Pipe Connector

ADDITIONAL ITEMS	
SMK-1	System Mounting Kit - Flange
SMK-6m	System Mounting Kit - Frame/Panel

PMK-1	Pipe Mounting Kit
GCK	Gauge Conversion Kit
ILF-8	1/2" In-Line Filter Kit
RCF-8	1/2" Remote Cube Filter
EPSK-1	Explosion Proof Switch Kit (GRP C, D)
EPSK-1A	Explosion Proof Switch Kit (GRP A-D)
GPSK-1	General Purpose Switch Kit
RAH	Remote Alarm Horn
RAB-1	Div. 1 Remote Alarm Beacon
RAB-2	Div. 2 Remote Alarm Beacon

ENCLOSURE PROTECTION VENTS

ONE VENT REQUIRED WITH EACH SYSTEM	
EPV-4-SA-00	Straight w/Spark Arrestor
EPV-4-SA-90	Rt Angle w/Spark Arrestor

WARNING NAMEPLATES

EWN-1	Class I Enclosure Warning
ETW	Enclosure Temperature Warning

INSTALLATION & OPERATION MANUAL

129-0216	Inst. & Operation Manual
----------	--------------------------

ONE (1) ENCLOSURE WARNING NAMEPLATE & ONE (1) INSTALLATION & OPERATION MANUAL ARE PROVIDED WITH EACH SYSTEM

Protected under U.S. Patent #5,101,710

Type Y, Z & Ex [nP]

3000 SERIES