



EHHVL 031 Fan Heater 100-400W

The compact HVL 0314 high-performance fan heater prevents formation of condensation and provides an evenly distributed interior air temperature in enclosures. For large OEM use, this fan heater can also be provided without the fan, in which case the OEM/customer must provide a fan which meets the minimum airflow requirements



200W/300W/400W Heater

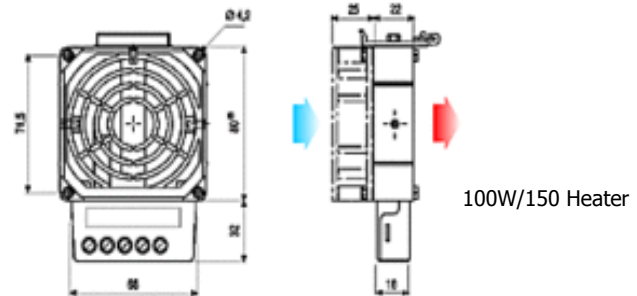
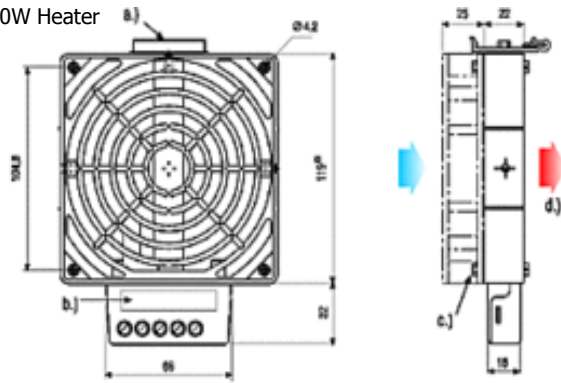

Caution: Heater may only be operated with fan. Operating without a fan creates the danger of overheating.

Technical Data

Heating element	high performance cartridge
Overheat protection	built-in temperature limiter
Heater body	die-cast aluminum, glass bead finish
Connection	3-pole terminal AWG 14 max. (2.5mm ²), torque 0.8Nm max
Connection housing	plastic, UL 94V-0, black
Mounting	clip for 35mm DIN rail, EN 60 715
Mounting position	horizontal
Operating/Storage temp	-49 to +158°F (-45 to +70°C)
Protection class/Protection type	I (grounded) / IP20
Axial fan, ball bearing	service life 50,000h at 77°F (25°C)
Air flow, free blowing	see table below
Axial fan connection	2-pole terminal AWG 14 max. (2.5mm ²), terminals L2/N2
Approvals	UL File No. E187294 (all), VDE (230VAC only)

Part No - 120VAC	Part No - 230VAC	Heating Capacity	Min airflow (free blowing)	Dimensions (as mounted)	Weight (approx)
EHHVL031100120	EHHVL031100230	100W	20 cfm (35m ³ /h)	1.85x3.15x4.41" (47x80x112mm)	1.3 lbs
EHHVL031150120	EHHVL031150230	150W	20 cfm (35m ³ /h)	1.85x3.15x4.41" (47x80x112mm)	1.3 lbs
EHHVL031200120	EHHVL031200230	200W	63 cfm (108m ³ /h)	1.85x4.68x5.94" (47x119x151mm)	2.0 lbs
EHHVL031300120	EHHVL031300230	300W	63 cfm (108m ³ /h)	1.85x4.68x5.94" (47x119x151mm)	2.0 lbs
EHHVL031400120	EHHVL031400230	400W	63 cfm (108m ³ /h)	1.85x4.68x5.94" (47x119x151mm)	2.0 lbs

4421 Tradition Trail Plano TX 75093
 (972) 964 - 2700 or (800) 836 - 7472 • Fax: (972) 964 - 2755
 Web www.iscenclosurecooling.com • Email: iscinfo@iscsales.com