

CLASS I APPLICATIONS
2 Cubic Feet Maximum
CLASS II APPLICATIONS
10 Cubic Feet Maximum

MODEL 1001A

TYPE Y OR Z

PRESSURIZATION / PURGING SYSTEM INSTALLATION & OPERATION MANUAL



LPS Style
(Less Pressure Switch)



WPS & WPSA Style
(With Pressure Switch)



CSA Approval applies to
WPS Style EXP Pressure Switch Only

ISC Sales, Inc. / Plano, Tx / www.iscsales.com / 972-964-2700 or 800-836-7472 / Since 1988

"Terms & Conditions of Sale" information is printed on every order acknowledgement; copies are available upon request.

We reserve the right to make modifications and no guarantee of the accuracy of the information contained herein is given.

© 2003 Pepperl+Fuchs® Inc., Twinsburg, Ohio 511820, Dwg No. 129-0197 (Supersedes 1001A-IOM) Printed in U.S.A.

Table of Contents

Page 2	System Purpose and Description Purpose, System Description, Important Notes	Page 13	Pneumatic Tubing Requirements Protective Gas Supply Requirements, Pneumatic Connection Requirements
Page 3	Identifying Your System Defines specific features of the system	Page 14	Tubing Installation LH, RH, TM, BM, WM, FM & PM Tubing Configurations
Page 4	General Information System & Material Specifications, System Accessories, Spare Parts, Tools & Test Equipment	Page 15	Tubing Connection Diagrams LH, RH, TM, BM, WM, FM, & PM Configuration Connection Points, Pneumatic Diagram
Page 5	Enclosure and Device Design Design Requirements, Adjacent Enclosures, Device Ventilation, Temperature Limitations	Page 16	Electrical Supply Requirements Wiring Requirements, Enclosure Power & Alarm Signal, Enclosure Wiring Methods & Connections
Page 6	Installation Overview Installation Diagram	Page 17	Conduit Installation Electrical & WPS Style Conduit and Connection Parts
Page 7	Getting Started Establishing Connection Sizes, Determining Enclosure Inlet & Outlet Connection Locations	Page 18	Set-Up Procedure Class I & Class II Set-up
Page 8	System Mounting LH, RH, TM, BM & WM Configurations, FM & PM Configurations	Page 19	Operating Sequence Class I & Class II Operation
Page 9	Special Mounting Information ECK, ILFK Connection Diagram, Typical Panel Mount Diagram	Page 20	Trouble - Shooting Procedures Trouble-shooting Chart
Page 10	Mounting Plate Dimensions Mounting Plate Dimension Diagrams	Page 21	Warranty and Liability Statement Warranty Notes, General Terms, Limitations
Page 11	Mounting Plate Dimensions (cont.) Mounting Plate Dimension Diagrams	Page 22	Customer Notes
Page 12	Hardware Mounting Optional Enclosure Protection Vent, Warning Nameplates	Page 23	System Maintenance Regular Maintenance, Long term Maintenance, Maintenance Schedule
		Page 24	Systems Identification & Application Information

Purpose

Pepperl+Fuchs' Bebcos EPS System's purpose is to allow the use of general purpose or non-rated electrical or electronic devices, with exception to devices which produce excessive heat, utilize combustible gas, or expose arcing contacts to the hazardous atmosphere, in NEMA (National Electrical Manufacturers Association) 4 or 12 enclosures in the place of explosion proof NEMA 7 enclosures. Other purposes include heat, moisture and dust contamination prevention.

Description

Model 1001A is an enclosure pressurization or purging system that operates on a supply of compressed instrument air or inert gas. It regulates and monitors pressure within sealed (protected) enclosures, to prevent combustible dust accumulation or remove and prevent flammable gas or vapor accumulations. In Class II areas, the system maintains a "safe" (1.0") pressure. In Class I areas, the system accomplishes four air exchanges and maintains a "safe" (0.25") pressure. These processes reduce the hazardous (classified) area rating within the enclosure(s), in accordance with the NEC - NFPA 70, Article 500, NFPA 496 and ISA ds12.4

Important Notes

One (1) permanent file copy and one (1) operations copy of this Manual must be studied and retained by the operator of this System. User's Agents are responsible for transferring this Manual to the user, prior to start-up.

The contents of this manual have been arranged to allow the use of this product as a stand-alone device on equipment and enclosures supplied by the user or its agents. The Manual's parameters encompass a combination of both National Fire Protection Association (NFPA) requirements and Pepperl+Fuchs, Inc. requirements. Pepperl+Fuchs therefore acknowledges the use of NFPA 496 as a guideline, that we have enhanced certain NFPA requirements and that additional information has been compiled to complete this document. The Manual is intended as a complete guide and must be considered, unless specifically stated otherwise, that all directives contained herein are requirements for safe, practical and efficient use of this product.

This System is not intended for use to protect enclosures or devices which contain ignitable concentrations of gases or vapors. This exclusion generally applies to process or product analyzing systems equipment.

All specifications are subject to change without notice.

Identifying Your System

This Enclosure Protection System is offered in various styles. For proper installation and operation, examine the System Model Number Nameplate to identify the System Style, Area Classification, and Type, as noted below.

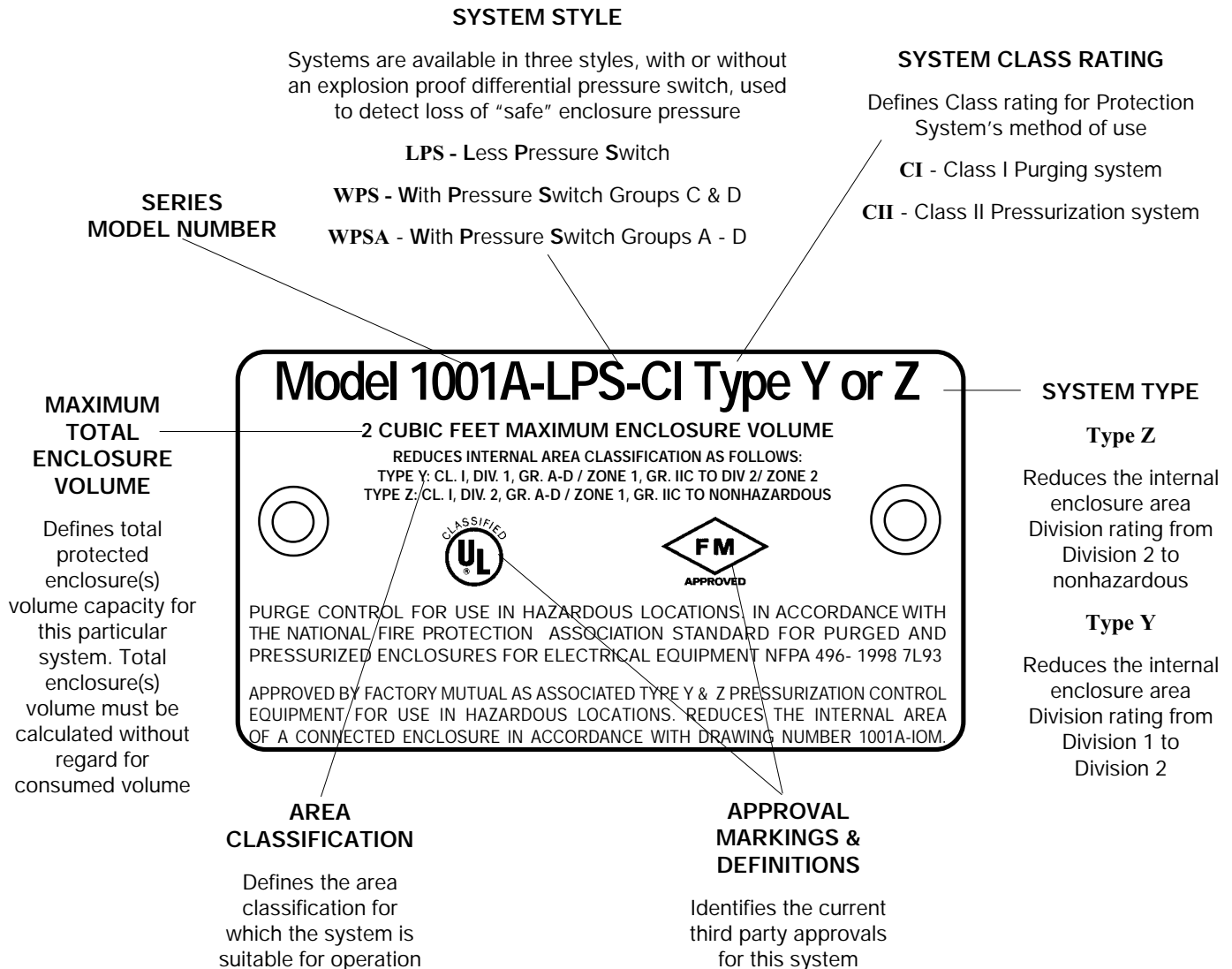

To assist you through the installation and operation of your pressurization / purge system, Pepperl+Fuchs, Inc. has provided the following information boxes throughout this manual. This information is intended to clarify certain differences between the model styles and configurations and to warn the user / installer of potential dangers of electrical shock or enclosure over pressurization.

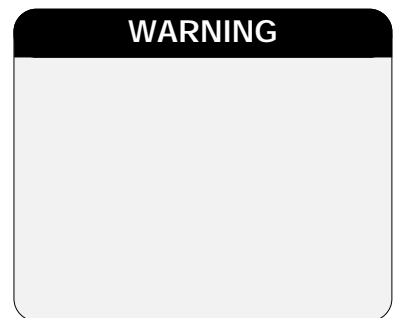
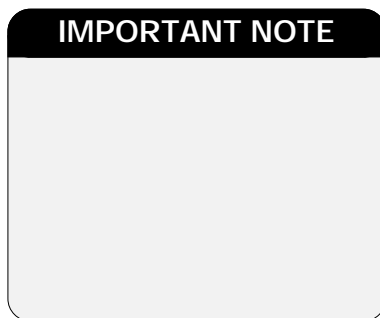

General Information

System Specifications

System Dimensions:	See Pages 10 & 11
Shipping Weight (lbs.):	LPS - 5, WPS - 10
Operating Temp. Range:	40° F - 120° F
Supply Pressure Range:	* 5 -120 PSI max.
Supply Requirements:	Clean Air or Inert Gas
Safe Press. (CI/CII):	0.25" / 1.0"
Safe Pressure Flowrate:	** 0.1-3.5 SCFH/Cubic Ft.
System Supply Fitting:	1/4" Tube Fitting
Enclosure Supply Fitting:	1/4" Tube Fitting
Enclosure Reference Fitting:	1/4" Tube Fitting
Switch Setting (WPS & WPSA Only):	0.15" ± 0.02"
WPS & WPSA Pressure Switch Wiring:	1/2" FPT
Switch Contact Ratings:	
WPS Style:	120 VAC, 15 Amps
WPSA Style:	*** 120/240 VAC, 10 Amps, 28 - 125 VDC

- * With Enclosure Protection Vent - 120 PSI maximum
Without Enclosure Protection Vent - 5 PSI maximum
- *** WPSA style switch requires 120/240 VAC supply voltage

In order to comply with the NFPA 496 standard requiring protection against over pressurization of the protected enclosure, the installer must install one of the following items in addition to the enclosure protection system.

- a) Install a Enclosure Protection Vent on the protected enclosure.
- b) Install a tamper-proof regulator upstream of the enclosure protection system's system supply inlet to pre-regulate protective gas supply to 5 PSI max.

In addition, for small, tightly sealed enclosures, or to compensate for a fluctuating protective gas supply, it may be necessary to pre-regulate the protective gas supply to a constant 5 PSI regardless of whether an Enclosure Protection Vent is installed. This will reduce the amount of "drifting" that can normally occur when maintaining a "Safe" pressure inside a protected enclosure. The pre-regulation can be accomplished by installing the TR-10 or TR-10G Tamper-Proof Regulator accessories or equivalent.

For applications which require a steady "Safe" pressure setting or for protective gas supplies which may have dramatic pressure fluctuations, it may be necessary to utilize the the PR-10 or PR-10G self relieving Precision Regulators or equivalent to pre-regulate the protective gas supply to a constant 5 PSI (please consult factory for more information).

** Enclosure integrity determines actual flow rate

Material Specifications

Regulator Body:	Zinc w/ Enamel Finish, Brass
Regulator Handle:	Polycarbonate
Enclosure Pressure Gauge:	ABS Plastic
Tube Fittings:	316 SS Forged Body
Tubing:	316 SS 1/4" .035 Welded
System Nameplates:	Silkscreened Lexan® & SS
Fastener Hardware:	Zink Plated & Stainless Steel
Mounting Plate:	316 14 Ga #3 Brush SS
EXP Pressure Switch Body:	Anodized Cast Alum.
Enclosure Warning Nameplate:	Silkscreened SS

Recommended Spare Parts

Qty	Description	Part # (supercedes)
1	Enclosure Pressure Indicator-CI	510023 (001000)
1	Enclosure Pressure Indicator-CII	513235 (001027)
1	Enclosure Pressure Control Regulator	513315 (002000)
1	Installation & Operation Manual	129-0197
1	Group C - D Pressure Switch-CI	510044 (001080)
1	Group A - D Pressure Switch-CI	510045 (001085)
1	Group E - G Pressure Switch-CII	513242 (001082)
1	Enclosure Warning Nameplate-CI	513008 (EWN-1)
1	Enclosure Warning Nameplate-CII	513009 (EWN-2)

Please call and reference the above part number for current spare parts pricing. Immediate pricing is available to all confirmed customers.

Installation Tools & Testing Equipment

- 1/2" chuck drill
- Complete set of drill bits
- 1/2" conduit knockout punch or 0.875" hole saw
- Complete set of tubing, conduit bending, instrument fitting and electrical craftsman hand tools
- 0 - 250 scfh flowmeter (connected upstream of the Protection System to determine air consumption and flow during set-up procedure)

Model 1001A System Accessories

Optional Enclosure Protection Vents

EPV-1-SA-00	Straight w/ Spark Arrestor
EPV-1-SA-90	Rt Angle w/ Spark Arrestor

Additional Items

SMK-1, -4 or -6	System Mounting Kit
EPSK-1	Class I, Group C - D Pressure Switch Kit
EPSK-1A	Class I, Group A - D Pressure Switch Kit
EPSK-2	Class II, Group E - G Pressure Switch Kit
GPSK-1	Class I, General Purpose Switch Kit
GPSK-2	Class II, General Purpose Switch Kit
RAH	Div. 1 Remote Alarm Horn
RAB-1	Div. 1 Remote Alarm Beacon
RAB-2	Div. 2 Remote Alarm Beacon
LCK	L Fitting Conduit Kit
TCK	T Fitting Conduit Kit
PIAD	Purgeable Instrument Access Door
TR-10	Tamper-Proof Regulator
TR-10G	Tamper-Proof Regulator w/ Gauge
PR-10	Precision Regulator
PR-10G	Precision Regulator w/ Gauge

Enclosure & Device Design

Enclosure Design Requirements

1. All windows must be shatterproof and sized as small as possible.
2. All NFPA 496 required markings must be placed on or near **all** enclosure doors and covers.
3. The enclosure must withstand an internal pressure of ten (10) inches of water without sustaining permanent deformation and resist all corrosive elements in the surrounding atmosphere.
4. All lightweight objects in the enclosure, such as paper or insulation, must be firmly secured.
5. The enclosure should be constructed from materials such as metal or non-static polycarbonate to meet or exceed NEMA 4 or 12 performance requirements, but does not require third party approval.
6. The installation of obstructions or other barriers which block or impede the flow of protective gas must be avoided.
7. The creation of air pockets or other areas which trap flammable gases within the enclosure or devices must be avoided.
8. The enclosure should be located in an area where impact hazards are minimal.
9. If the enclosure is nonmetallic and contains equipment which utilizes or switches power loads greater than 2500 VA, it must be constructed from substantially noncombustible materials, such as materials designed to meet or exceed ANSI/UL94 ratings of 94 V-0 or 94 5V.

Adjacent Enclosures

1. Adjacent enclosures must be protected by one of the following means:
 - a) purged or pressurized in series with the protected enclosure;
 - b) purged or pressurized separately; or
 - c) protected by other means; e.g. explosion proof enclosures, hermetically sealed devices or intrinsic safe circuits.
2. Adjacent purged or pressurized enclosures must be designed to meet all construction requirements above.

Total Volume Calculation

1. The total volume of all pressurized enclosures, devices and wireways must be considered.
2. All enclosure, device and wireway volumes must be calculated without consideration of internally consumed space.

Device Ventilation

1. Enclosed devices within the protected enclosure which do not exceed 1.22 cubic inches of free volume do not require ventilation to the protected enclosure.
2. If the free volume of an internal device exceeds 1.22 cubic inches it must be protected by one of the following means:
 - a) ventilated on the top and bottom sides with one (1) square inch of opening for each four hundred (400) cubic inches of volume within the internal protected enclosure, at a minimum diameter of one (1) quarter inch;
 - b) purged in series with the protected enclosure or be purged separately; or
 - c) protected by other means; e.g. explosion proof enclosures, hermetically sealed devices or intrinsic safe circuits.

Temperature Limitations

1. The enclosure must have no surface area which exceeds 80 percent of the flammable or ignitable substance's auto-ignition temperature.
2. Internal devices which exceed this temperature must be protected by one of the following manners:
 - a) The device is enclosed in a chamber which is UL, FM or CSA listed as a hermetically sealed device which prohibits the entrance of flammable or ignitable substance, and maintains a surface temperature below temperature limits.
 - b) It can be proven by testing that the devices will not ignite the substance involved.
 - c) The device is purged in a separate enclosure that bears an ETW (Enclosure Temperature Warning Nameplate). Devices may only be accessed after power has been removed and the device has been allowed to cool to safe temperature, or the area is positively known to be nonhazardous.

Installation Overview

Typical Left Hand Configuration Installation Diagram

Model 1002-WPS-LH Shown

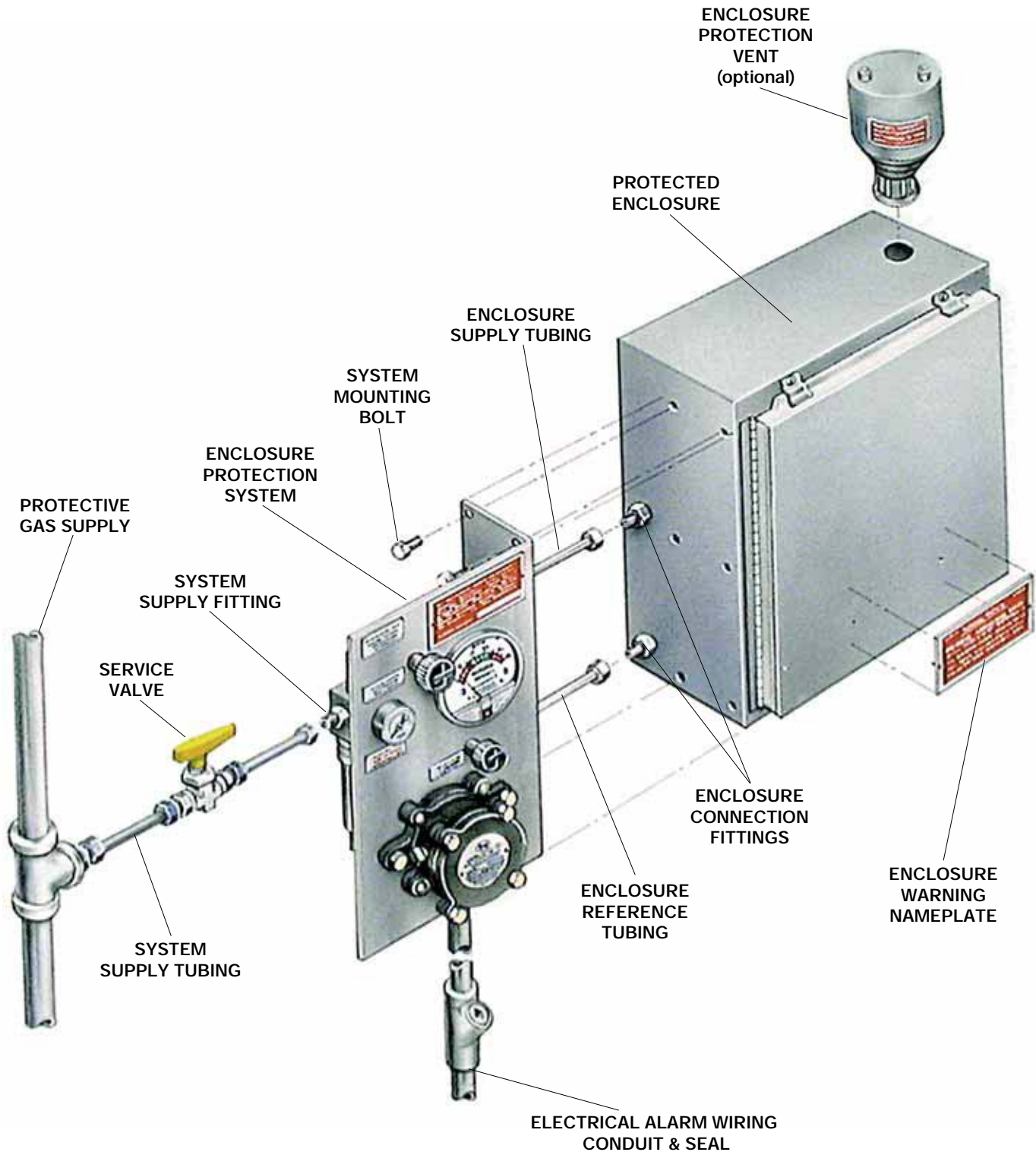

Getting Started

Establishing Connection Sizes, Lengths & Bends

TYPICAL SINGLE PROTECTED ENCLOSURE CONNECTIONS

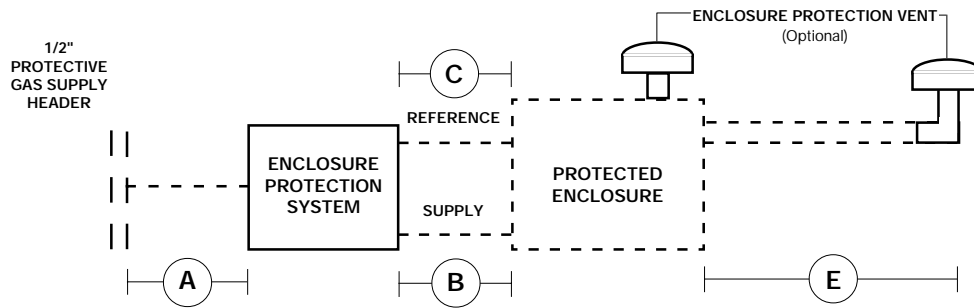

Description	A	B	C	D	E
	System Supply Tubing	Enclosure Supply	Enclosure Reference	Multi - Enclosure Connections	Optional Remote Venting
Tubing or Pipe Diameter	1/4" O.D. Tubing Fully Reamed	1/4" O.D. Tubing Fully Reamed	1/4" O.D. Tubing Fully Reamed	1/2" I.D. Pipe Fully Reamed	1/2" I.D. Pipe Fully Reamed
Maximum Tubing / Pipe Length and Maximum Number of Bends / Elbows	20 Feet 10 Bends	5 Feet 5 Bends	20 Feet 10 Bends	10 Feet 5 Elbows	30 Feet 5 Elbows

TYPICAL MULTIPLE PROTECTED ENCLOSURE CONNECTIONS

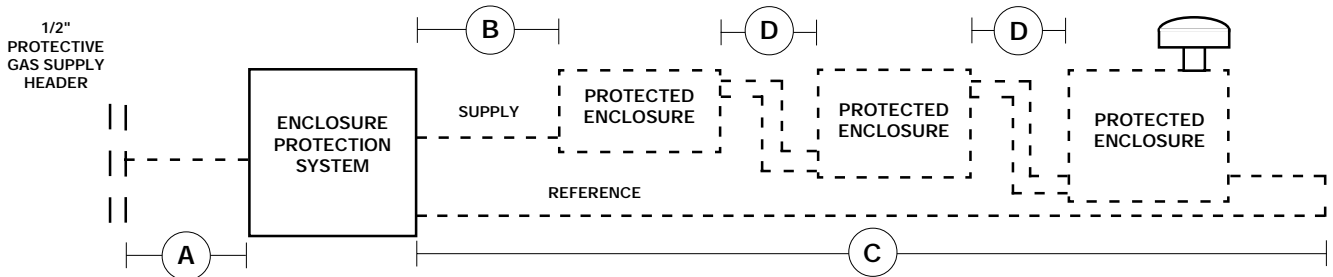

HELPFUL HINTS

To ensure adequate protective gas flow to the protected enclosure(s), all piping and tubing must be fully reamed. Precautions must be taken to prevent crimping and other damage to protective gas piping and tubing. When protecting multiple enclosures with a single enclosure protection system, the enclosures must be connected in series from the smallest to the largest to ensure adequate protective gas flow.

Determining Enclosure Inlet & Outlet Connection Locations

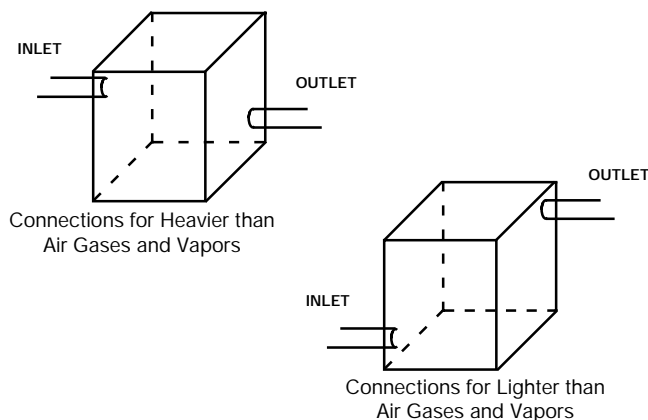

HELPFUL HINTS

If flammable gases are lighter than air, the inlet connection to each enclosure must enter near a bottom corner. The outlet connection, for an optional enclosure protection vent or piping to an adjacent protected enclosure, must exit near an extreme opposite top corner.

If flammable gases are heavier than air, inlet and outlet connections must be reversed.

In all cases, the most prevalent gas must determine the location of inlet and outlet connections.

System Mounting

IMPORTANT NOTES

The system should be mounted at EYE LEVEL.

Care must be taken to ensure the system and all protruding components are clear of all enclosure accesses (doors and covers) and conduit, pipe, tubing or cable entries.

LH, RH, TM, BM and WM configurations are intended for mounting adjacent to the protected enclosure.

LH, RH, TM & BM configurations are also suitable for 2" schedule 40 pipe mounting. In addition, these configurations can be accessorized with an ECK (Enclosure Connection Kit). (See page 9)

Systems furnished with the ECK are not compatible for pipe mounting or multiple enclosure applications.

Determine the mounting configuration of your system using the diagrams on pages 10 & 11.

Remove and save the manila envelope (containing the enclosure warning nameplate) which may be taped to the outer surface of the mounting flange.

Although all systems are factory tested and calibrated, we strongly suggest a bench test of basic functions prior to installation.

Mounting LH, RH, TM, BM & WM Configurations

Surface mounting Systems with ECK accessory

1. Verify dimensions of the System's mounting holes and connection fittings in reference to the applicable drawing on pages 10 and 11.
2. Upon confirmation of dimensions, transfer mounting hole pattern from drawing to the intended surface.
3. Check for internal obstructions which could hinder bolt fastening and protective gas flow, drill and ream the mounting holes before mounting the system.
4. Remove locknuts on enclosure connection fittings.
5. Secure the system to the protected enclosure using one (1) SMK-1 mounting kit or equivalent - four (4) 1/4" x 3/4" stainless steel bolts, nuts and lock washers.
6. Install the locknuts on the enclosure connection fittings from inside of the protected enclosure, ensuring that fittings seat directly against enclosure through the system mounting plate flange.

Surface mounting Systems without ECK accessory

1. Transfer hole pattern of System mounting plate to intended surface.
2. Check for obstructions hindering bolt fastening, drill and ream the mounting holes before mounting the system.
3. Secure the system to the enclosure, or other mounting surface, using one (1) SMK-1 mounting kit or equivalent - four (4) 1/4" x 3/4" stainless steel bolts, nuts and lock washers.

Pipe mounting Systems without ECK accessory

1. Locate 2" schedule 40 pipe, (vertical for LH & RH, horizontal for TM & BM) within five (5) feet of protected enclosure.
2. Ensure system is mounted in a true vertical position, secure the system to pipe, using one (1) a PMK-1 mounting kit or equivalent - two (2) 1/4" x 2" stainless steel "U" bolts, nuts and lock washers.

Mounting FM & PM Configurations

HELPFUL HINTS

FM and PM configurations are designed to mount through a panel cutout one (1) inch smaller than the overall height and width of the system mounting plate, using clips and fasteners provided with the SMK-4 or SMK-6 mounting kit. This design feature eliminates the need to drill the system mounting bolt holes in the protected enclosure.

FM configurations are intended for mounting adjacent to the protected enclosure.

PM configurations are intended for mounting through a cutout in the protected enclosure surface.

1. Transfer panel cutout pattern to the intended surface.
2. Check for obstructions which could prohibit bolt fastening or system pneumatic connections.
3. Cut panel cutout pattern on the intended surface.
4. Deburr all cutout surfaces.
5. Secure system to enclosure using SMK-4 or SMK-6 mounting kit, or equivalent 1/4" x 3/4" stainless steel nuts, bolts, mounting clips and lock washers.

Special Mounting Information

Typical Example of Factory Installed ECK & ILFK Accessories

(ECK) - FACTORY INSTALLED ENCLOSURE CONNECTION KIT ACCESSORY

Provides factory installed tubing and fittings for enclosure supply and reference connections.

(ILFK) - FACTORY INSTALLED IN-LINE FILTER KIT ACCESSORY

Provides an 8.5 oz. capacity, 40 micron protective gas supply filter, factory installed on the inlet side of the enclosure pressure control regulator.



Model 1001A-LPS-LH shown

Typical Examples of Surface, Pipe, Panel & Frame Mounted Systems



Typical Surface Mounted System
(Model 1002-LPS-CI-Z-LH shown)



Typical Pipe Mounted System
(Model 1002-LPS-CI-Z-LH shown)



Typical Panel/Frame Mounted System
(Model 1002-LPS-CI-Z-PM shown)

Mounting Plate Dimensions

Model 1001A

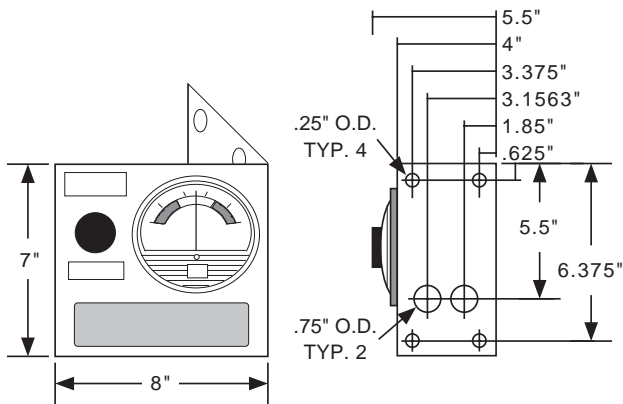

1001A-LPS-LH
(Left Hand Configuration)

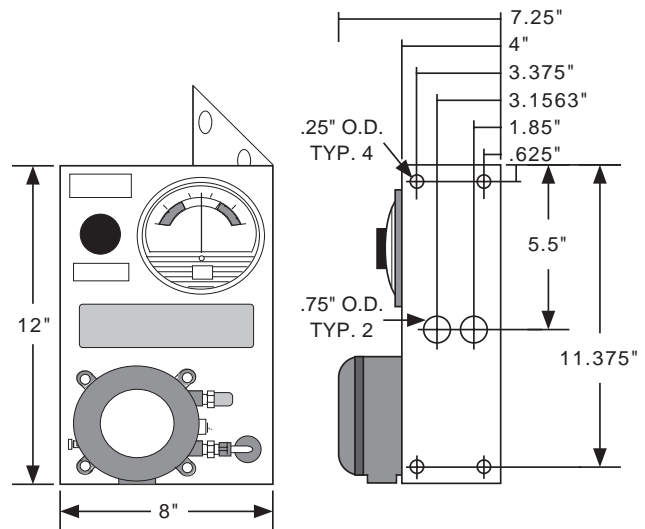

1001A-WPS & WPSA-LH
(Left Hand Configuration)

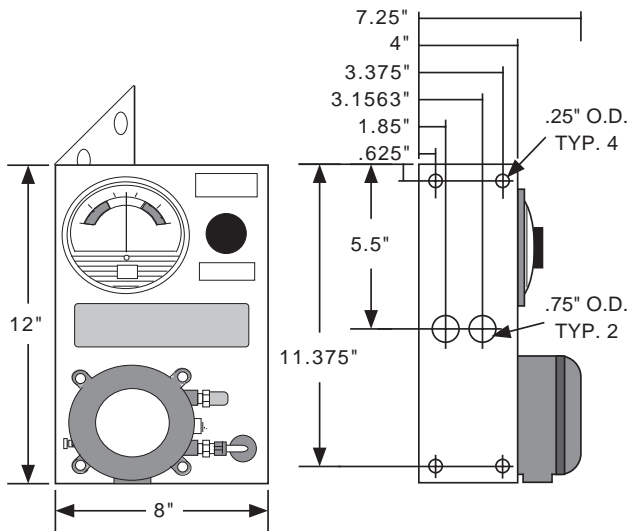

1001A-WPS & WPSA-RH
(Right Hand Configuration)

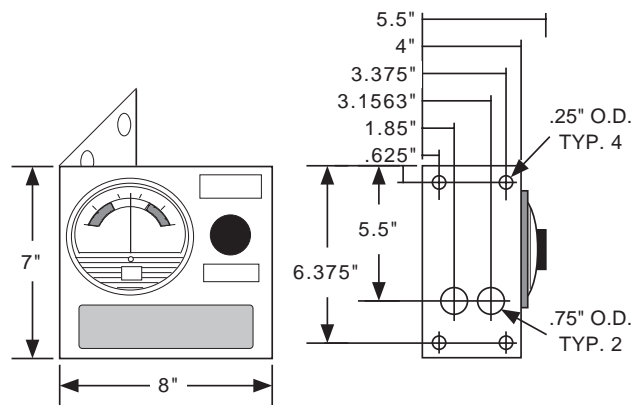

1001A-LPS-RH
(Right Hand Configuration)

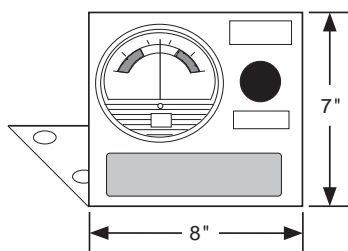

1001A-LPS-TM
(Top Mount Configuration)

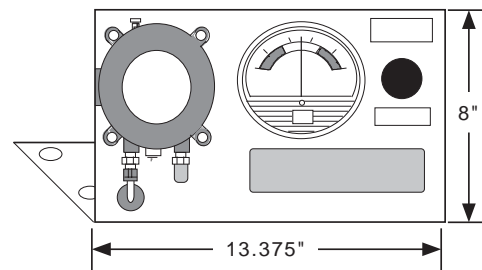

1001A-WPS & WPSA-TM
(Top Mount Configuration)

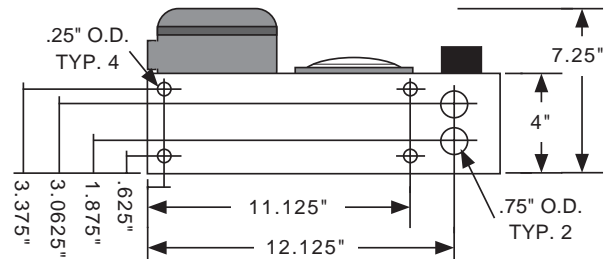
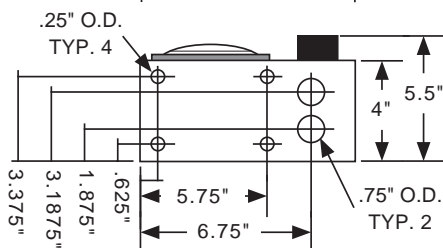

Mounting Plate Dimensions (cont.)

Model 1001A

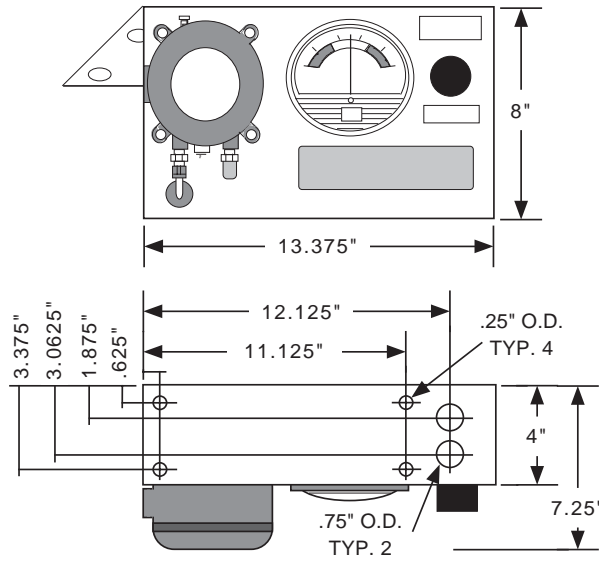

1001A-WPS & WPSA-BM
(Bottom Mount Configuration)

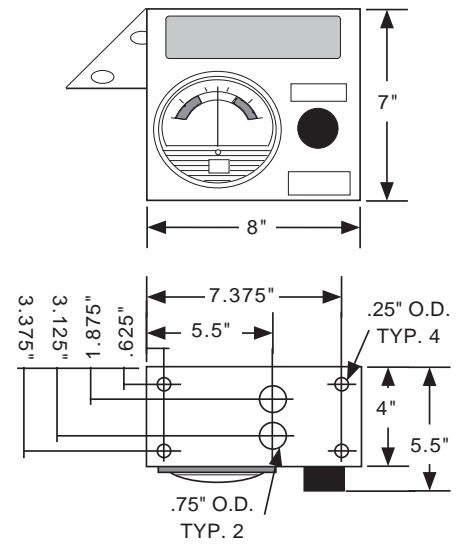

1001A-LPS-BM
(Bottom Mount Configuration)

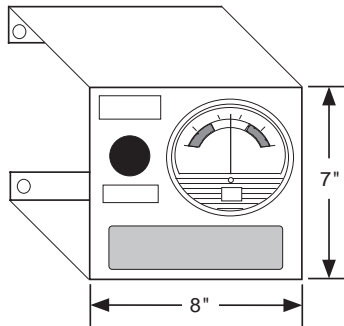

1001A-LPS-WM
(Wall Mount Configuration)

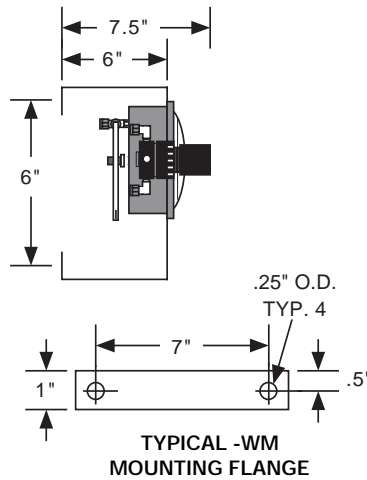

TYPICAL -WM
MOUNTING FLANGE

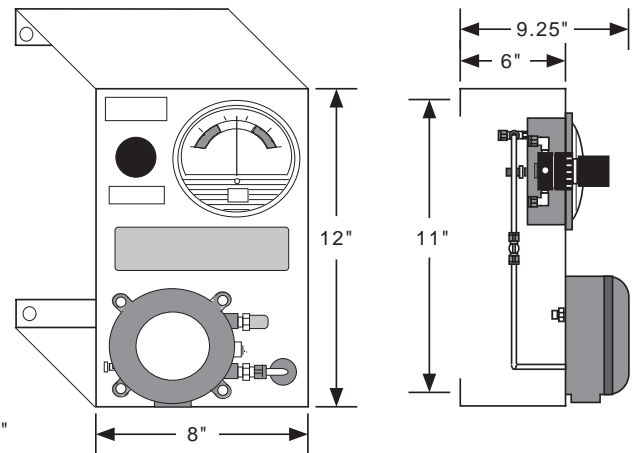

1001A-WPS & WPSA-WM
(Wall Mount Configuration)

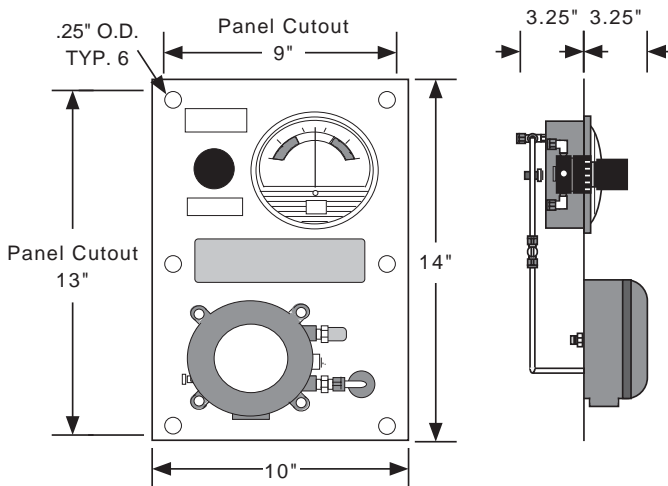

1001A-WPS & WPSA-FM
(Frame Mount Configuration)

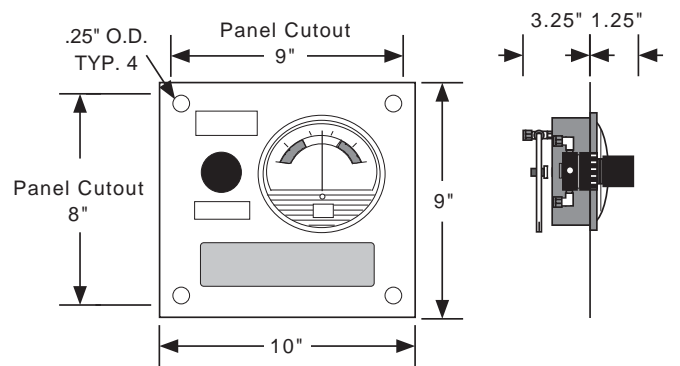

1001A-LPS-FM & 1001A-LPS-PM
(Frame & Panel Mount Configuration)

Hardware Mounting

Optional Enclosure Protection Vent

All configurations must be mounted in a true vertical position.

The vent must be located to provide access for routine testing of the vent's flapper assembly. A minimum 8" clearance is required below the vent opening.

1. Determine the vent's mounting configuration, i.e.; -00 vertical mount or -90 side mount. (see photos below)
2. Determine vent location and layout vent mounting hole on the protected enclosure. (as determined on page 7, "Getting Started")
3. Using a 0.875" hole saw or 1/2" conduit punch, drill and deburr the enclosure protection vent mounting hole.
4. Remove the hub mounting nut from the vent hub and place the hub, with O-ring intact, through the mounting hole. The O-ring must be on the outside of the protected enclosure.
5. Reinstall the hub mounting nut to the mounting hub from inside the protected enclosure and tighten.



EPV - 1 - SA - 00
Vertical Mount



EPV - 1 - SA - 90
Side Mount

Warning Nameplate(s)

An EWN (Enclosure Warning Nameplate) must be located in a prominent position on or near **all** enclosure accesses (doors and covers).

One (1) EWN is provided with each system, located in the manila envelope taped to the mounting flange of the system. Additional EWN's are available from Pepperl+Fuchs.

All EWNs provide labeled spaces allowing the customer to mark the protected enclosure with: 1) a T Code (temperature identification number), 2) Class, Group and Division of surrounding area, and 3) NFPA pressurization Type X, Y or Z, as may be required by plant and local codes and is required by NFPA 496 section 2-11.

An ETW (Enclosure Temperature Warning nameplate) must be located in a prominent position on or near all enclosure accesses (doors and covers) when the temperature of an internal component exceeds 80 percent of the ignition temperature of the flammable vapor, gas or dust involved.

The ETW warns the operator to deenergize all equipment for a specified length of time, allowing the protected equipment to cool before opening the protected enclosure. The length of time required is determined by the customer and can be factory or field engraved.

All EWNs and ETWs are furnished with an adhesive back, but should also be riveted or screwed to the protected enclosure.



Enclosure Warning Nameplate - Class I



Enclosure Warning Nameplate - Class II



Enclosure Temperature Warning Nameplate

Pneumatic Tubing Requirements

Protective Gas Supply Requirements

The protective gas supply to the protection system must be a clean, instrument quality compressed air or nitrogen and must contain no more than trace amounts of flammable gas, vapor or dust.

The protective gas supply compressor intake must originate in a nonhazardous location. Suction duct passing through a hazardous location and the protection system tubing and piping must be fabricated from noncombustible materials suitable for prevailing hazards and environmental conditions.

The protective gas supply must originate from a dedicated instrument quality compressed air header (1/2" pipe or larger), no farther than twenty (20) feet from the protection system. Local compressors and gas cylinders should not be used before consulting with Pepperl+Fuchs.

The protective gas supply to the protection system must be equipped with a tamper-proof regulator set at 5 psi maximum.

Exception: If the protected enclosure(s) is equipped with a Pepperl+Fuchs Enclosure Protection Vent, the protective gas supply to the protection system must not exceed 120 psi maximum, 5 psi minimum. (See page 4, "System Specifications" for additional information concerning protective gas supply requirements.)



SC-4



NC-4

SYSTEM SUPPLY FITTINGS



EFC-



EBC-

ENCLOSURE SUPPLY & REFERENCE FITTINGS



EPC-10

MULTIPLE ENCLOSURE CONNECTION FITTING

Pneumatic Connection Requirements

ALL FITTINGS MAY BE CUSTOMER OR FACTORY FURNISHED

1. For system supply, one (1) SC-4 1/4" Male Straight Connector or one (1) NC-4 1/4" Male Elbow Connector or equivalent fitting per system.

NOTE: Above fitting is required only if protection system is furnished with an optional In Line Filter Kit (Model ILFK) accessory. See photo on page 9

One (1) Similar fitting which will connect the inert gas supply tubing to the inert gas supply header connection point and one (1) lot of 1/4" O.D., .035" wall thickness, welded or seamless stainless steel tubing.

2. For enclosure supply, one (1) EFC-4 1/4" Flush Connector, or one (1) EBC-4 1/4" Feed-Through Connector or equivalent fitting per system.
3. For enclosure reference, one (1) EFC-4 1/4" Flush Connector, or one (1) EBC-4 1/4" Feed-Through Connector or equivalent fitting per system.
4. One (1) lot of 1/4" O.D., .035" wall thickness, welded or seamless stainless steel tubing.

NOTE: Above fittings and tubing are not required if System is furnished with an Enclosure Connection Kit (Model ECK) accessory. See photo on page 9

5. For multiple enclosure connections, two (2) EPC-10 1/2" Pipe Mounting Hubs or equivalent and 1/2" 150# rated pipe couplings & unions per interconnection.

One (1) lot 150# rating 1/2" galvanized or aluminum pipe and fittings, fully reamed and unrestricted.

PM Pneumatic Connection Requirements

In addition to item numbers 1, 4 and 5 above, the following fittings are required for all PM configurations.

1. For system supply on PM configurations, one (1) additional EBC-4 or equivalent 1/4" Through Bulkhead Fitting per system is required.
2. For atmospheric reference, one (1) PRB-4 or equivalent 1/4" female bulkhead fitting and stainless steel sintered element is required.



PRB-4

SYSTEM ATMOSPHERIC REFERENCE FITTING

Tubing Installation

HELPFUL HINTS

All work must be performed by technicians qualified in pneumatic tubing and electrical conduit installation.

Pepperl+Fuchs recommends the use of .035" wall thickness, welded or seamless stainless steel tubing. If flexible tubing is used, it must be installed in a manner which will protect it from damage and corrosion.

Tubing LH, RH, TM, BM, WM & FM Configurations

System Supply Connections

1. Select or install a protective gas supply header tap, fitted with the proper tube size fitting and located within twenty (20) feet of the enclosure protection system.
2. If a service valve is placed between the protective gas supply header and the enclosure protection system, it must be installed in close proximity of the protected enclosure and be labeled in accordance with section 2-11.4 of the NFPA 496, 1998 edition.
3. Select the appropriate fittings required to connect the protective gas supply to the protection system regulator as determined on page 13, "Pneumatic Connection Requirements".
4. Determine appropriate tubing route from the protective gas supply header to the protection system regulator.
5. Bend tubing using industrial grade benders, check tubing fit to ensure proper seating between the tubing and fittings. Fully ream all tubing ends.
6. Install tubing and tighten all fittings to fitting manufacturer's specifications. Secure tubing to appropriate structural supports as required.

Enclosure Supply & Reference Connections

Systems supplied with an ECK (Enclosure Connection Kit), go to page 16 "Electrical Supply Requirements".

1. Choose location for the enclosure supply connection(s) based on the requirements on page 7, "Getting Started".
2. Place the enclosure reference connection fitting directly behind the enclosure protection system whenever possible. For systems protecting multiple enclosures in series, the enclosure reference connection fitting must be placed on the last enclosure in the series. (see page 7, "Getting Started")
3. Drill and deburr enclosure supply and reference fitting holes on the protected enclosure. Mount the fittings.
4. Determine appropriate route for the enclosure supply and reference tubing.
5. Bend tubing using industrial grade benders, check tubing fit to ensure proper seating between the tubing and fittings. Fully ream all tubing ends.
6. Install tubing and tighten all fittings to fitting manufacturer's specifications. Secure tubing to appropriate structural supports as required.

Tubing PM Configurations

Enclosure Bulkhead Fittings

1. Select the fittings required to install the System Supply, System Supply Bulkhead Fitting and Atmospheric Reference Bulkhead Fitting, (see page 13, "Pneumatic Tubing Requirements").
2. Choose location for the system supply bulkhead fitting. This fitting allows the protective gas supply to pass through the wall of a protected enclosure to the protection system's regulator supply inlet connection.
3. Choose location for the atmospheric reference bulkhead fitting. This fitting allows the enclosure pressure gauge to reference atmospheric pressure.
4. Drill and deburr system supply and reference bulkhead fitting holes in the protected enclosure. Mount the fittings.

System Supply & Reference Connections

1. Select or install a protective gas supply header tap, fitted with the proper tube size fitting and located within twenty (20) feet of the enclosure protection system.
2. If a service valve is placed between the protective gas supply header and the protection system, it must be in close proximity of the protected enclosure and labeled in accordance with section 2-11.4 of the NFPA 496.
3. Determine appropriate tubing route from the protective gas supply header to the system supply bulkhead fitting.
4. Determine appropriate tubing route from the system supply bulkhead fitting to the protection system regulator.
5. Determine appropriate tubing route from the atmospheric reference bulkhead fitting to the enclosure pressure gauge's reference inlet connection.
6. Bend tubing using industrial grade benders, check tubing fit to ensure proper seating between the tubing and fittings. Fully ream all tubing ends.
7. Install tubing and tighten all fittings to fitting manufacturer's specifications. Secure tubing as required.

Tubing Connection Diagrams

LH, RH, TM, BM, WM & FM Configuration Connection Points & Pneumatic Diagram



WPS & WPSA Style

Enclosure Pressure Gauge
Enclosure Reference Inlet
Venturi Orifice
Mounting Plate



LPS Style

System Supply Inlet
Enclosure Pressure Control Regulator
Enclosure Supply Outlet

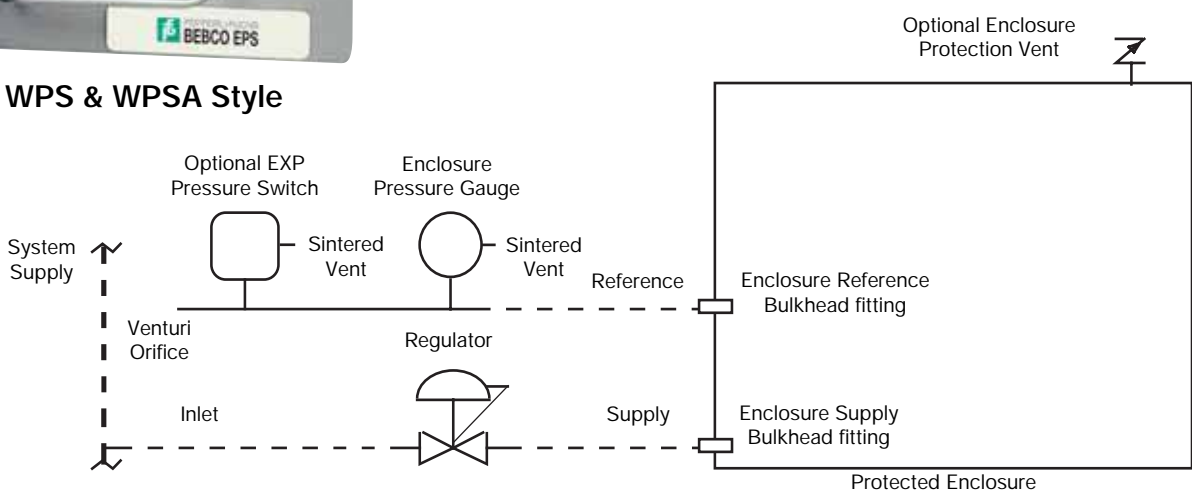

PM Configuration Connection Points & Pneumatic Diagram

Enclosure Pressure Gauge
Atmospheric Reference Inlet
Mounting Plate



System Supply Inlet
Enclosure Pressure Control Regulator
Enclosure Supply Outlet

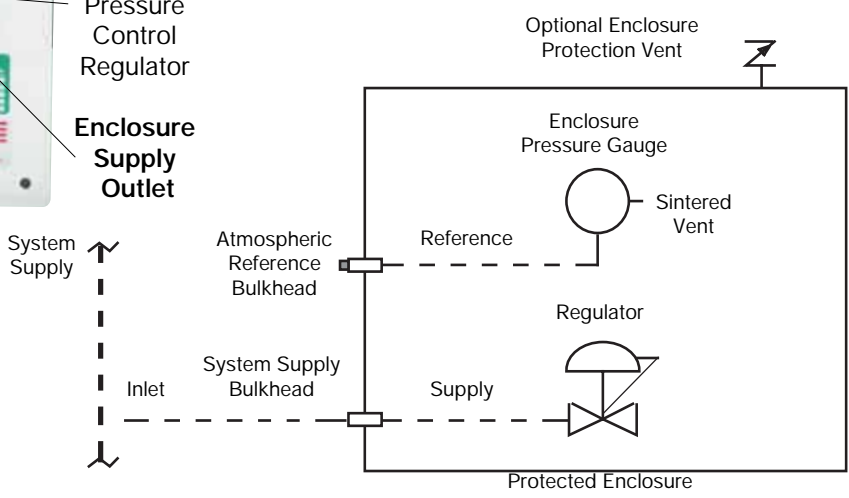

HELPFUL HINT
Pneumatic Connections are bolded.

Electrical Supply Requirements

General Wiring Requirements

WARNING

THIS DEVICE CONTAINS ELECTRICAL PARTS WHICH CAN CAUSE SHOCK OR INJURY

All electrical connections, conduit and fittings on the protected enclosure must be suitable for the hazardous location in which they are installed. In addition, all conduit and wire must be installed in accordance with NEC articles 500-1, 500-2 or 500-3 as required and all relevant plant and local codes.

Note: Do not use seals on conduit used as a protected "wireway" to supply protective gas to adjacent protected enclosures. The same conduit can be utilized for both electrical and pneumatic service to an adjacent protected enclosure(s), provided the conduit is oversized to allow a minimum free clearance equal to or larger than the pipe size required between multiple enclosures as stated on page 7, "Getting Started".

Enclosure Power Requirements

The protected enclosure(s) electrical power source must originate from a circuit breaker or fused disconnect suitable for the hazardous location in which it is installed. The switch must be located within fifty (50) feet of the protected enclosure(s) and the protection system and be properly marked.

Alarm Signal Requirements

The WPSA style pressure switch requires a 120 VAC power supply in addition to the alarm signal. The WPS and WPSA Style systems alarm signal may originate from the protected enclosure if the alarm signal is disconnected by the protected enclosure's circuit breaker or fused disconnect as stated in Enclosure Power Requirements above.

The protected enclosure(s) alarm signal power may also originate from outside of the protected enclosure. In this application, the protected enclosure may be used as a "wireway" to pass alarm signal wiring from the power source to the alarm device, if the wiring is isolated and properly labeled. In addition, appropriate conduit seals must be provided outside of the protected enclosure separately.

IMPORTANT NOTE

NFPA 496 requires the use of an alarm or an indicator to detect the loss of safe enclosure pressure. In addition, the NFPA 496 requires that if an indicator alone is utilized, a protective gas supply alarm must also be installed between the last valve in the protective gas supply and the protected enclosure. Therefore, the protective gas supply to all LPS Style systems must be equipped with the above mentioned protective gas supply alarm. Exception: Systems utilizing an EPSK or GPSK enclosure pressure loss alarm switch accessory will satisfy the above mentioned NFPA requirement.

Typical Enclosure Wiring Methods

Protected enclosures must be wired similar to explosion proof enclosures, in accordance with **Article 501-504** of the 1999 National Electric Code - **NFPA 70**.

Single conductor wiring must be placed in rigid metal conduit, seal-flex conduit or other mediums approved for use in the hazardous location surrounding the protected enclosure. Although the 1998 edition of NFPA 496 does not require conduit seals on pressurized enclosures in a division 2 area, Pepperl+Fuchs strongly recommends the use of a conduit seal as the most practical way to prevent excessive leakage through conduit connections.

While explosion proof enclosures require conduit seals on all cable entries, in accordance with **NFPA 70, Sections 501-5**, protected enclosure cable entries can be sealed in accordance with **Section 501-5** which permits the use of compression gland fittings or other sealed cable entry fittings, as opposed to approved conduit seals, if the wiring method is otherwise suitable for the hazardous location.

In conclusion, there are two primary goals. First, the installer should ensure all associated wiring and cable is protected by pressurization or other means, such as explosion proof conduit or intrinsic safety barriers. Secondly, the installer must ensure all associated conduit and wireways are sealed to conserve protective gas, unless they are used to supply protective gas to other enclosures or devices.

Typical Enclosure Wiring Connections

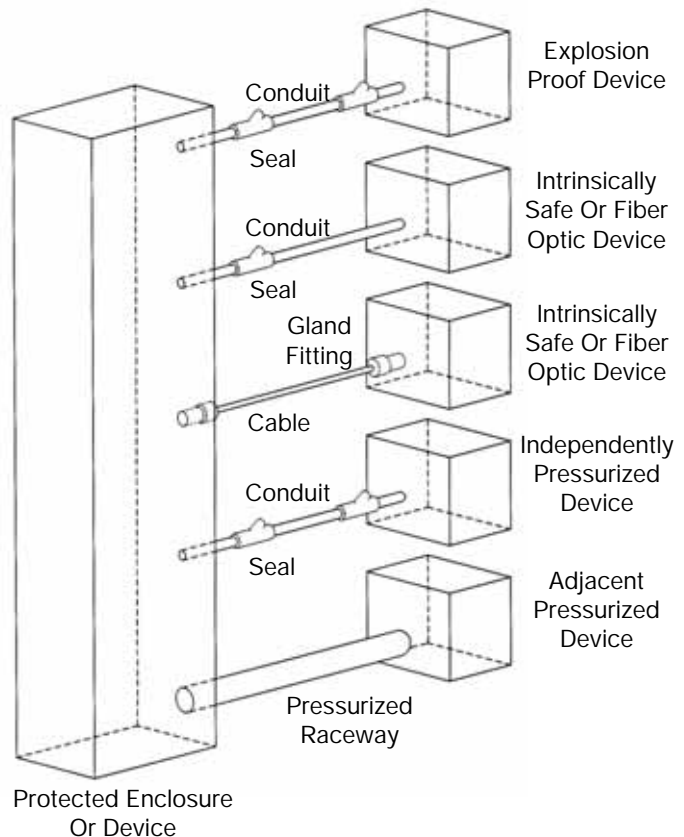

Conduit Installation

Electrical Conduit

1. Choose the location for the enclosure's electrical conduit connection(s) based on the requirements on page 16, "Electrical Supply Requirements".
2. Drill and deburr enclosure conduit fitting holes in the protected enclosure. Mount the fittings.
3. Determine appropriate route for the enclosure electrical and power alarm signal conduit.
4. Measure, cut and thread conduit, check conduit fit to insure proper seating. Fully ream all conduit.
5. Install conduit and tighten all fittings to fitting manufacturers specifications. Secure conduit to appropriate structural supports as required.
6. Seal all conduit with an approved compound prior to operation of the protection system.

WPS & WPSA Style Conduit

WPS and WPSA style systems provide electrical contacts for audible or visual alarm devices that signal a loss of protected enclosure pressure. WPS and WPSA style systems are calibrated to alarm at 0.15" for Class I applications and 0.50" for Class II applications. The switches are suitable for hazardous (classified) outdoor locations. Wiring must be installed with a seal and conduit fittings suitable for the area. Alarm circuit power may be derived from the protected enclosure power source or an intrinsically safe alarm signal source. All associated alarm devices must be protected by suitable means (explosion proof, purged or intrinsically safe).

WPS & WPSA Style Conduit Connection Parts

Fitting Kits Can Be Factory Furnished

1. For WPS and WPSA Style EXP pressure loss alarm switch connected to an enclosure mounted alarm, one (1) LCK (L fitting Conduit Kit) or equivalent conduit elbow, coupling and seal fittings.
2. For WPS and WPSA Style EXP pressure loss alarm switch connected to a remote mounted alarm, one (1) TCK (T fitting Conduit Kit) or equivalent conduit tee, coupling and seal fittings.
3. One (1) lot 150# rating 1/2" galvanized or aluminum pipe.

HELPFUL HINT
It may be impractical to pour all electrical conduit seals prior to installation in the field. However, all conduit connections must be sealed for proper testing and operation of the Enclosure Protection System. Therefore, the use of temporary seals such as duct seal or masking tape for bench or shop testing, prior to final field installation may be used.

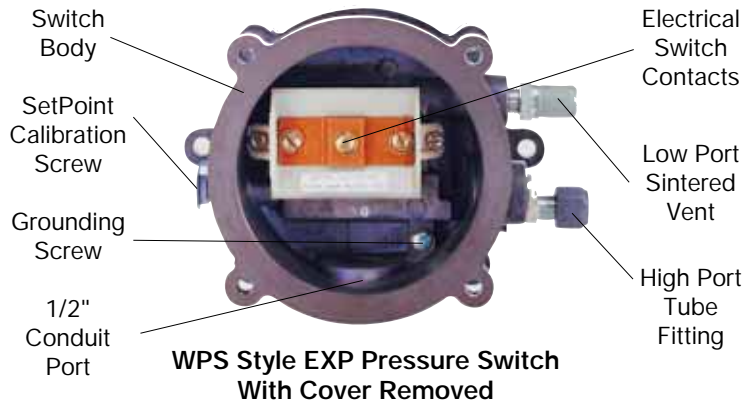

TCK "T" Fitting Conduit Kit



LCK "L" Fitting Conduit Kit

Set-up Procedure

HELPFUL HINTS

The term "Safe" pressure for purposes of this manual is defined as follows;

Class I = a minimum .25 inch of water column pressure.

Class II = a minimum 1.0 inch of water column pressure.

Regulator may be in the locked position upon arrival.

To adjust regulator, pull handle to outward position.

To test the vent's operation, gently prod the vent flapper open with a soft pointed object, (example: eraser end of a pencil) ensuring that the vent valve works freely. On vertically configured vents, this can be accomplished from within the protected enclosure. Side mounted -90 configured vents can be tested by removing the conduit plug at the bottom of the mounting tee. Multiple operations require only one test per day if enclosure is not opened or left unattended.

Class I Purging Set-up

1. Close the Enclosure Pressure Control Regulator fully by turning counterclockwise (CCW).
2. Temporarily connect the inert gas supply to a 0 to 250 SCFH flowmeter. Connect the outlet of the flowmeter to the Enclosure Pressure Control Regulator.
3. Check operation of Enclosure Protection Vent (if utilized).
4. Seal enclosure(s) and adjust Enclosure Pressure Control Regulator by opening slowly clockwise (CW) to set a "Safe" pressure on the Enclosure Pressure Indicator.
NOTE: If pressure setting is difficult to stabilize or set, (see page 20, "Trouble-Shooting Procedures").
5. When safe enclosure pressure is stabilized, measure flow of inert gas supply through Protection System, to calculate required exchange time, based on the Class I exchange time chart.
6. Install and tighten all bolts on the pressure loss alarm switch (if utilized). Ensure the conduit is sealed with approved compounds. Energize power to Switch and alarm system (if utilized) and test the function of the alarm system.
7. Cease testing and remove test equipment (Flowmeter).
8. Connect the inert gas supply directly to the Enclosure Pressure Control Regulator.

CLASS I VOLUME EXCHANGE TIME CHART

MEASURED FLOW	REQUIRED EXCHANGE TIME
0.10 SCFM / 6 SCFH	40 Minutes per Cubic Foot
0.25 SCFM / 15 SCFH	16 Minutes per Cubic Foot
0.50 SCFM / 30 SCFH	8 Minutes per Cubic Foot
0.75 SCFM / 45 SCFH	5.5 Minutes per Cubic Foot
1 SCFM / 60 SCFH	4 Minutes per Cubic Foot
2 SCFM / 120 SCFH	2 Minutes per Cubic Foot
3 SCFM / 180 SCFH	1.5 Minutes per Cubic Foot
4 SCFM / 240 SCFH or greater	1 Minute per Cubic Foot

NOTE: The volume exchange time chart is based on a four (4) enclosure volume exchange. Multiply the required exchange time above by 2.5 for applications requiring a ten (10) volume exchange (motors).

Regardless of enclosure volume or system flow rate, it is required that operators withhold power to the enclosure while inducing Class I exchange, for at least five (5) minutes. Normal exchange time calculations should be doubled if large obstructions block inert gas flow.

The Start-Up Instruction Nameplate Exchange Time Slot will be blank, but the unit may feature a set of direct factor nameplates with self-adhesive backing such as "TEN MINUTES", for application to the start-up instructions, dependent on how the system was specified and purchased. Field modification of this nameplate, to show a direct factor, is acceptable as noted above if the method used to mark the nameplate does not deface the instructions listed. Materials used for the marking must be indelible and withstand prevailing environmental conditions.

IMPORTANT NOTE

Operators must secure wrist or stop watch to manually time Exchange Cycle for Class I applications.

Class II Pressurization Set-up

1. Close the Enclosure Pressure Control Regulator fully, by turning it counterclockwise (CCW).
2. Remove all traces of combustible dust from the protected enclosure.
3. Check operation of Enclosure Protection Vent (if utilized).
4. Seal enclosure(s) and adjust Enclosure Pressure Control Regulator by opening slowly clockwise (CW) to set a "Safe" pressure on the Enclosure Pressure Indicator.
5. Install and tighten all bolts on the pressure loss alarm switch (if utilized). Ensure the conduit is sealed with approved compounds. Energize power to Switch and alarm system (if utilized) and test the function of the alarm system.
NOTE: If pressure setting is difficult to stabilize or set, (see page 20, "Trouble-Shooting Procedures").

Operating Sequence

WARNING

Do not exceed a "Safe" pressure with the Enclosure Pressure Control Regulator.

Operators must follow step-by-step sequence of the Start-Up Instructions Nameplate on the Protection System.

Class I Purging Operation

With the inert gas supply connected, enclosure power deenergized and alarm system energized (if utilized).

1. Carefully read Start-Up Instruction Nameplate on system.
2. Check operation of the Enclosure Protection Vent (EPV-1, if utilized), opening it manually several times, (see page 18, "Helpful Hint").
3. Seal protected enclosure(s).
4. Open Enclosure Pressure Control Regulator, by turning CW, to set Enclosure Pressure Indicator at "Safe" pressure, the Pressure Loss Alarm Switch should then activate to silence the alarm system (if utilized).
5. Ensure the Protection System Enclosure Pressure Indicator maintains a "Safe" pressure for one (1) minute.
6. Standby for the exchange time as specified on the Instruction Nameplate, then energize the protected enclosure power.
7. Ensure the Enclosure Pressure Indicator maintains a "Safe" pressure before leaving system unattended.

Class II Pressurization Operation

With the inert gas supply connected, enclosure power deenergized and alarm system energized (if utilized) . .

1. Carefully read Start-Up Instruction Nameplate on system.
2. Check operation of the Enclosure Protection Vent (EPV-1, if utilized), opening it manually several times, (see page 18, "Helpful Hint").
3. Remove all traces of combustible dust.
4. Seal protected enclosure(s).
5. Open Enclosure Pressure Control Regulator by turning CW to set Enclosure Pressure Indicator at "Safe" pressure, the Pressure Loss Alarm Switch should then activate to silence the alarm system (if utilized).
6. Ensure the Protection System Enclosure Pressure Indicator maintains a "Safe" pressure for one (1) minute.
7. Energize the protected enclosure power.
8. Ensure the Enclosure Pressure Indicator maintains a "Safe" pressure before leaving system unattended.

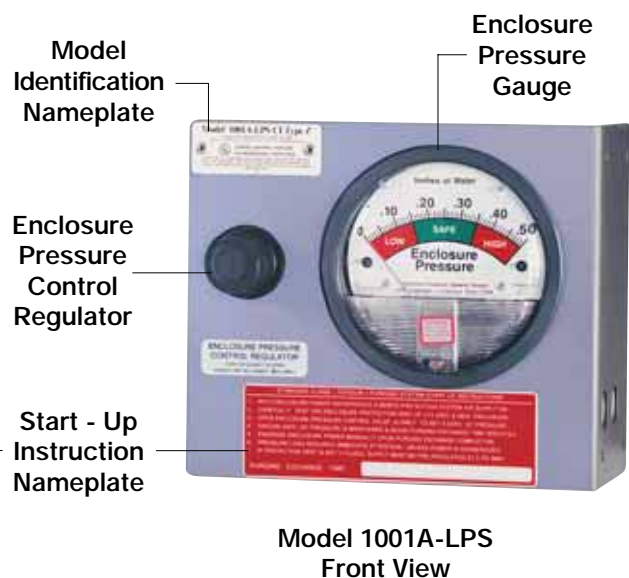

Trouble - Shooting Procedures

Problem or Fault	Possible Causes	Corrective Action
Enclosure pressure control regulator will not hold a safe pressure.	Leakage around gasketing, covers, seams, piping and tubing connections, conduit connections and electrical conduit seals of the enclosure.	Tighten enclosure latches: Where tightening is not feasible, and gasketing materials are not practical, holes or gaps can be closed with silicone sealant applied from inside the protected enclosure.
Enclosure pressure indicator reading is difficult to stabilize.	Insufficient enclosure leakage or opening of the venturi orifice is crimped too small.	Remove the orifice, cut off the crimped end and ream the tube, then recrimp and reinstall the tube to note effect. As tube is shortened, reamed, and recrimped, sensitivity decreases, allowing easier adjustment of setpoint on the enclosure.
Enclosure Pressure Indicator "Drifts" up or down from the "Safe" pressure setting.	Application involves a small, tightly sealed enclosure and/or a fluctuating protective gas supply.	Pre-regulate the protective gas supply upstream of the enclosure protection system to 5 PSI maximum. For dramatic fluctuations in the protective gas supply, it may be necessary to utilize a self-relieving low flow precision regulator to pre-regulate the protective gas supply.
Enclosure pressure loss alarm switch does not appear to be operating.	Pressure switch is out of calibration. Pressure switch has not been energized (WPSA style systems only)	Calibrate by slowly adjusting counterclockwise to decrease the setpoint, and clockwise to raise the setpoint. (Do not attempt to calibrate the switch until all efforts to make the switch respond properly have failed) Verify 120 VAC has been applied to power contacts of WPSA style
Problems persists, or if the system does not appear to be operating properly.	Persisting problems	Contact ISC Sales, Inc. Customer Service Department at (800-836-7472)

This section covers the most common problems documented with these systems. Any problems not covered in this section should be addressed directly to our factory. Please address all service needs to Pepperl+Fuchs, Inc. - Customer Service Department at (330) 486-0002.

ISC Sales, Inc. / Plano, TX / www.iscsales.com / 972-964-2700 or 800-836-7472 / Since 1988

Warranty Terms and Conditions

PEPPERL+FUCHS STANDARD 18-MONTH WARRANTY

Subject to the conditions and requirements set forth herein, P+F warrants the products covered by the respective warranties to be free from defects in material and workmanship under normal and proper usage for the respective time periods listed above from the date of shipment from P+F (or from an authorized representative or distributor of P+F). In addition, certain specific terms apply to various warranties.

THESE EXPRESS WARRANTIES ARE IN LIEU OF AND EXCLUDE ALL OTHER REPRESENTATIONS MADE — BOTH EXPRESS AND IMPLIED, INCLUDING ANY IMPLIED WARRANTIES OF MERCHANTABILITY, FITNESS FOR A PARTICULAR PURPOSE, OR THAT THE PRODUCTS ARE FREE OF ANY CLAIM OF ANY THIRD PERSON BY WAY OF INFRINGEMENT OR THE LIKE, and are also in lieu of and exclude any promise, description, affirmation of fact, sample model or representation, oral or written, which may be part of an order or made by a representative of P+F or otherwise. This WARRANTY shall not apply to any product which has been subject to misuse, negligence, or accident, or to any product which has been modified or repaired, improperly installed, altered or disassembled (except according to P+F's written instructions) or any product if the machinery, equipment, or production line to which the product is originally connected or on which the product is originally installed is abandoned, changed, substituted, moved or replaced or if the product is removed from such machinery, equipment or production line or other original application.

This WARRANTY is subject to the following conditions:

- 1) This WARRANTY is limited to the electronic and mechanical performance only, as expressly detailed in the product specifications and NOT to cosmetic performance.
- 2) This WARRANTY shall not apply to any cables attached to, or integrated with the product. However, it shall apply to cables sold separately by P+F.
- 3) This WARRANTY shall not apply to any products which are stored, or utilized, in harsh environmental or electrical conditions outside P+F's written specifications.
- 4) The WARRANTY is applicable only to products shipped from P+F subsequent to January 1, 1992.
- 5) All claims under this WARRANTY must be made in writing within thirty (30) days of the date on which the defect is (or, with reasonable diligence, should have been) discovered.

PRODUCTS TO WHICH STANDARD 18-MONTH WARRANTY APPLIES

Ultrasonic sensors, level controls, photoelectric sensors, read-write ID systems, encoders, counters, signal conditioners, purge/pressurization systems and all products with electromechanical relays or circuit breakers.

CONSIDER SAFETY AND PROTECTION PRECAUTIONS

P+F takes great care to design and build reliable and dependable products; however, some products can fail eventually. You must take precautions to design your equipment to prevent property damage and personal injury in the unlikely event of failure. As a matter of policy, P+F does NOT recommend the installation of electronic controls as the sole device FOR THE PROTECTION OF PERSONNEL in connection with power driven presses, brakes, shears and similar equipment and, therefore, the customer should build in redundancy or dual control using approved safety devices for these applications.

DELIVERY

Pepperl+Fuchs® Inc. will deliver its products F.O.B. from its warehouse, place of manufacture or other place from which the products are actually shipped within the U.S.A.

ISC Sales, Inc. / Plano, TX / www.iscsales.com / 972-964-2700 or 800-836-7472 / Since 1988

SYSTEMS IDENTIFICATION & APPLICATION INFORMATION	
Date of Installation	_____
Unit Serial #	_____
Item	_____
Customer P.O.#	_____
Customer Project#	_____
Service	_____
Type	_____
Features	_____
Application	_____

NOTES: _____

Local Sales Representative	
ISC Sales, Inc.	Since 1988
4421 Tradition Trail	
Plano, Texas 75093	
972-964-2700 or 800-836-7472	
URL: www.iscsales.com	