

Description

Model 2001C is a pressurization system that operates on a supply of compressed instrument air or inert gas. It regulates and monitors pressure within sealed (protected) enclosure(s), in order to prevent combustible dust accumulation. Intended exclusively for Class II Areas, the system is designed to maintain a "safe" (1.0") pressure. In addition, the system includes an electrical power control unit (EPCU) that monitors system operation and controls enclosure power. All start-up requirements must be satisfied before the EPCU will energize power to the enclosure(s). This process reduces the hazardous (classified) area rating within the enclosure(s), in accordance with the NEC - NFPA 70, Article 500, NFPA 496 and ISA 12.4.

Basic Operation

In accordance with system instructions, start-up requires the air supply to be engaged and EPCU power to be energized. The operator is then required to remove all dust from the protected enclosure(s). The enclosure protection vent (if used) must be tested and enclosure(s) must be sealed. The EPCU power control switch must be activated and the system will self-test. The enclosure pressure control regulator is used to set a safe reading on the enclosure pressure gauge. The enclosure power will energize after a brief pause, when safe pressure is stable. Loss of safe pressure causes the EPCU to deenergize power to the protected enclosure(s). The system includes form "C" contacts for audible or visual alarm systems.

Model 2001C



STD Style
(Standard)



Standard Model Applications

Model Number:	2001C-CII Type X
Designation:	Pressurization System
Enclosure Volume:	250 ft ³ max.
UL & FM Certified:	Cl. II, Div. 1, Group E-G
Rating Reduction:	Div. 1 to Unclassified

2000
SERIES

Type X

Type X

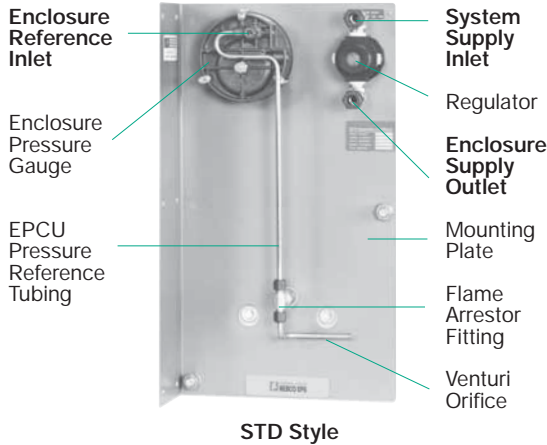

STD Style

CONNECTION POINTS SHOWN ABOVE IN BOLD TEXT ON SYSTEM DIAGRAM

Material Specifications

Regulator Body:	Zinc w/Enamel Finish
Regulator Handle:	Polycarbonate
Enclosure Pressure Gauge:	Alum. w/Enamel Finish
Tube Fittings:	316 SS Forged Body
Tubing:	316 SS 1/4" .035 Welded
System Nameplates:	Silkscreened Lexan® & SS
Fastener Hardware:	SS Screws & Bolts
Mounting Plate:	316 14 Ga #3 Brush SS
EPCU Enclosure Body:	Bead Blast Cast Alum.
Enclosure Warning Nameplate:	Silkscreened SS

Lexan® is a registered trademark of the General Electric Corporation

Simplified EPCU Redundant Logic Diagram

OPERATION

Signal (1) from SPS is sent to μ P, GAL and SPCR coil. During start-up, GAL verifies all μ P functions. GAL & μ P must receive uninterrupted signal from SPS to prevent logic resetting. After GAL verifies all start-up procedures, it sends "power enabled" Signal (2) to PER coil. Then, μ P sends "power request" Signal (3) through the SPCR and PER contacts to EPR coils.

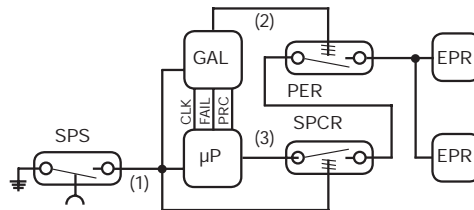

- SPS - SAFE PRESSURE SWITCH
- GAL - GATE ARRAY LOGIC
- μ P - MICROPROCESSOR
- PER - POWER ENABLED RELAY
- SPCR - SAFE PRESSURE CONFIRMATION RELAY
- EPR - ENCLOSURE POWER RELAY

Electrical Wiring Diagram

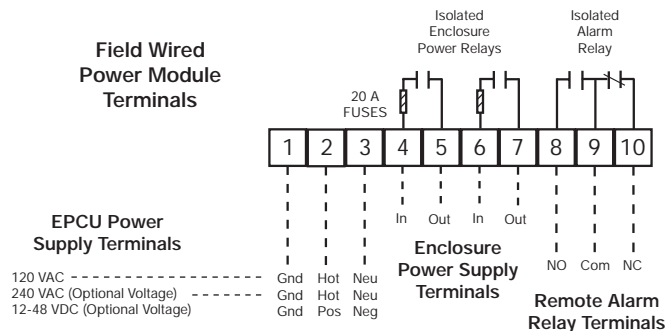

System Specifications

System Dimensions:	See Page 58
Shipping Weight:	38 lb
Temp. Range:	-20°F to +120°F
Supply Pressure Range:	* 5 - 120 psi max.
Supply Requirements:	Clean air or inert gas
Safe Press. Setpoint:	1.0" @ Safe Press.
Safe Press. Flowrate:	** 0.1 - 3.5 SCFH
System Supply Port:	1/2" Tube Fitting
Enclosure Supply Fitting:	1/2" Tube Fitting
Enclosure Reference Fitting:	1/4" Tube Fitting
EPCU Conduit Port Size:	1/2" FPT
EPCU Power Requirements:	120 VAC 60 Hz 1Ø
(European 220 voltage only)	240 VAC 50 Hz 1Ø
(All voltage ratings are factory set)	*** 12-48 VDC
EPCU Power Consumption:	500 mA
Power Relay Contacts:	20 A @ 240 VAC
	20 A @ 28 VDC
	*** 20 A @ 48 VDC
Alarm Relay N.O. Contact:	20 A @ 240 VAC
	20 A @ 28 VDC
Alarm Relay N.C. Contact:	15 A @ 240 VAC
	10 A @ 28 VDC

- * With EPV-4 Vent - 120 psi max. to 5 psi min. Systems installed without Vent must be equipped with tamper proof regulator set to 5 psi max.
- ** Enclosure integrity determines actual flow rate
- *** Optional 12-48 VDC Power Module Specifications

EPCU Description

The Pepperl+Fuchs 2000 Series EPCU is a factory programmed, field adjustable, microprocessor controlled unit featuring full status indication, redundant gate array logic and electromechanical relays. The EPCU is constructed from four major items: (1) a power module, (2) a pressure switch module, (3) a logic module and (4) a power mode selector switch. The sections are linked with polarized cable, and the boards are stacked in the EPCU enclosure on standoffs.

Basic EPCU Operation

When power is "off", the EPCU is at rest, alarm and power relays are deenergized, and the LED display is off. When power is switched "on", the EPCU performs a self-test of LED display and logic functions. The unit will then start-up. Class II units must detect a 0.50" pressure to energize the alarm relay. The enclosure power relays energize after a brief delay. Loss of safe pressure on the unit causes alarm and power relays to deenergize (see power control options for more information regarding EPCU operation).

EPCU Logic Module

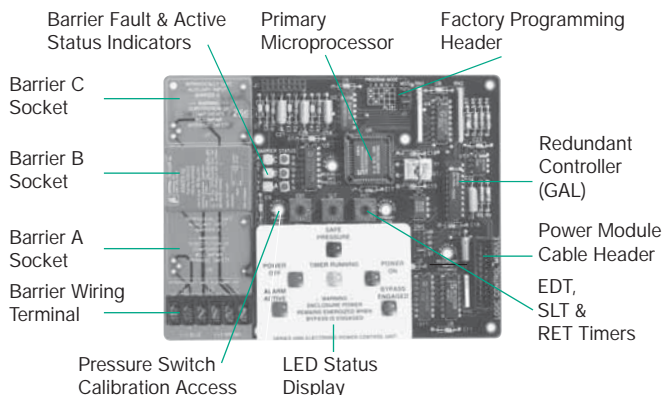

EPCU Pressure Switch Module

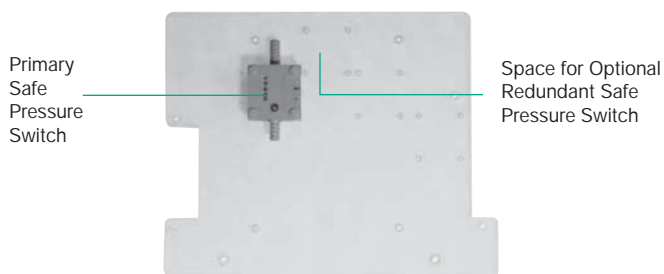

120/240 VAC EPCU Power Module

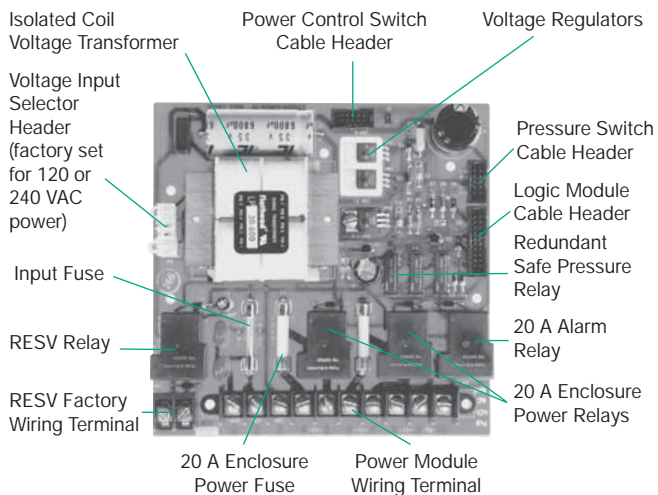

Assembled Electrical Power Control Unit

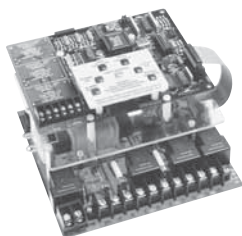

Optional 12-48 VDC EPCU Power Module

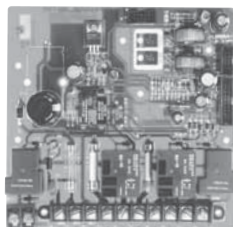

EPCU Features

LED DISPLAY INDICATORS

Power Off:	Enclosure Power Relays Deenergized
Power On:	Enclosure Power Relays Energized
Safe Pressure:	Enclosure Pressure > 0.50" w.c.
Alarm Active:	Enclosure Pressure < 0.50" w.c.
Bypass Engaged:	Control Bypass Active - CB Modes

Class II LED Displays

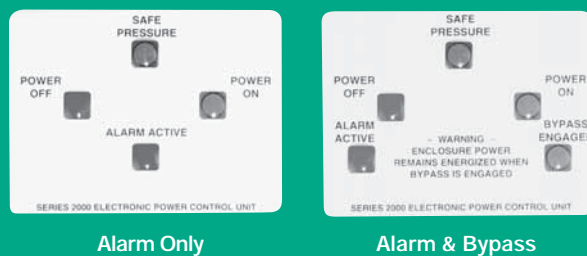

FIELD ADJUSTABLE TIMER FUNCTIONS

RET, EDT & SLT timers not functional on Model 2001B Systems

Power Control Options

NORMAL RUNNING (NR) MODE

EPCU features an on-off push-button power control switch to activate control functions. Switch must be depressed to initiate start-up. After completion of start-up, safe pressure must be lost or switch must be depressed to deenergize enclosure power relays.

CONDITIONAL BYPASS (CB) MODE

EPCU features an off-on-bypass power control switch to activate control functions. Switch must be set to "on" position to initiate start-up. After enclosure power is energized, safe pressure must be lost or switch must be set to "off" position to deenergize enclosure power. After enclosure power is energized, switch may be set to "bypass" position to temporarily latch enclosure power relays. A flashing LED then indicates bypass engaged, and the enclosure can be accessed without deenergizing power (performed under specific conditions). Following access, safe pressure must be reestablished to resume normal operation. At that time, the switch may be reset to the "on" position without disruption of enclosure power. Alarm relay normally deenergizes only upon loss of safe pressure, but can be programmed to deenergize when bypass is engaged, if specified at time of order.

2000 SERIES

Type X

System Accessories Diagram

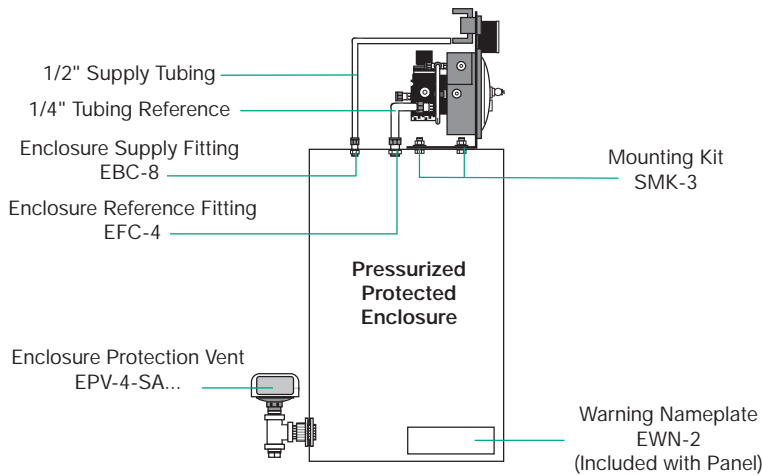

Model Number Designations

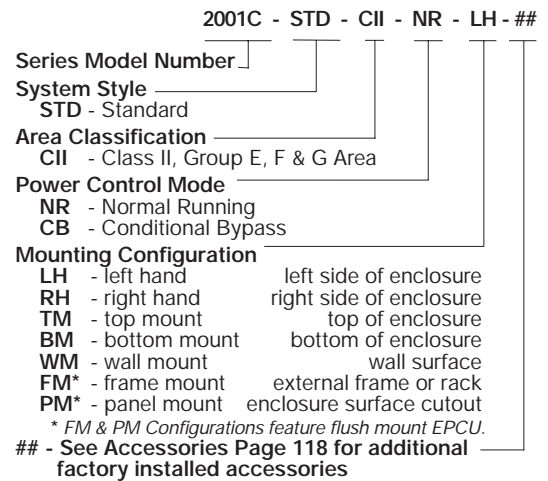

2000
SERIES

Type X

OPTIONAL INTRINSIC SAFETY BARRIERS DESCRIPTION & OPERATION

The EPCU Logic Module can accommodate up to three intrinsic safety barriers to interact with remote devices and affect operation of the EPCU. The barriers are installed and programmed by the factory at time of order, and they are designed to function either in conjunction with a customer furnished switch and a Pepperl+Fuchs furnished resistor network cable, or a Pepperl+Fuchs furnished proximity detector. Each barrier develops a low power signal to create a two-wire closed-loop circuit. Operational status of each barrier is indicated by a green LED to show active (closed switch) status, and by a red LED to show faulted (line breakage) cable status. All barriers can be reprogrammed to duplicate other barrier functions as required, upon specific request.

BARRIER PROGRAMMING OPTIONS

Barrier A Function - when switch opens

Disables start-up cycle
Deenergizes enclosure power and alarm relay
Functions parallel to safe pressure switch

Barrier B Function - when switch opens

Not programmed - custom applications only

Barrier C Function - when switch closes

Energizes RESV relay - custom applications only

Model 2001C System Accessories (See accessories page for complete details)

CONNECTION FITTINGS

EFC-4	1/4" Flush Connector
EFC-8	1/2" Flush Connector
EBC-8	1/2" Bulkhead Connector
EPC-14	1-1/2" Pipe Connector

ADDITIONAL ITEMS

SMK-2, -3 or -10	System Mounting Kit
RAH	Remote Alarm Horn
RAB-1	Div. 1 Remote Alarm Beacon
LCK	L Fitting Conduit Kit
TCK	T Fitting Conduit Kit

SRM-4000	Switch Resistor Module
NJ...	P+F Namur Sensor

INSTALLATION & OPERATION MANUAL

129-0210	Inst. & Operation Manual
----------	--------------------------

OPTIONAL ENCLOSURE PROTECTION VENTS

EPV-4-SA-00	Straight w/Spark Arrestor
EPV-4-SA-90	Rt Angle w/Spark Arrestor

WARNING NAMEPLATES

EWN-2	Class II Enclosure Warning
ETW	Enclosure Temperature Warning

FACTORY INSTALLED ACCESSORIES

IS1	Channel A Barrier
IS2	Channel B Barrier
IS3	Channel C Barrier
RP1	Redundant Safe Pressure Switch
L	Power Switch Key Lock Assembly

ONE (1) ENCLOSURE WARNING NAMEPLATE & ONE (1) INSTALLATION & OPERATION MANUAL ARE PROVIDED WITH EACH SYSTEM

Overall System Dimensions						
STD	LH - left hand	RH - right hand	TM - top mount	BM - bottom mount	WM - wall mount	FM or PM - flat panel
Height	20	20	10.50	10.50	20	22
Width	11	11	20.75	20.75	11	13
Depth	10.75	10.75	10.75	10.75	12.50	11.50

Dimensions in inches. Mounting dimensions available upon request. FM & PM panel cutout dimensions: 21h x 12w
Height & Width dimensions reflect mounting plate measurements. Depth dimension reflects overall measurement of system, including components.