

CLASS I APPLICATIONS
15 Cubic Feet Maximum

Description

Model 2002 is a Rapid Exchange® purging system which operates on a supply of compressed instrument air or inert gas. It is designed to regulate and monitor pressure of sealed (protected) enclosure(s), in order to rapidly remove and prevent flammable vapor accumulation within the enclosure(s). The system is designed to accomplish four air exchanges and maintain a "safe" (0.25") pressure on one or more enclosures not exceeding a total volume of fifteen cubic feet. A Bebcos Model EPV-2 Enclosure Protection Vent is required for proper operation. In addition, the system includes an electrical power control unit (EPCU) that monitors system operation and controls enclosure power. All start-up requirements must be satisfied before the EPCU will energize power to the enclosure(s). This process reduces the Hazardous (Classified) Area Rating within the enclosure(s), in accordance with the NEC - NFPA 70, Article 500, NFPA 496 and ISA ds12.4.

Basic Operation

In accordance with detailed instructions on the System, start-up requires the air supply to be engaged and EPCU power to be energized. The enclosure protection vent must be tested and the enclosure(s) must be sealed. The EPCU power control switch must be activated and the system will self-test. The enclosure pressure control valve is then used to manually set a safe reading on the enclosure pressure indicator. When safe pressure is stable, the Rapid Exchange® control valve is fully engaged by manual or automatic means (dependent on System Style, see below). Upon completion of the Rapid Exchange® cycle, (five minutes minimum) the Rapid Exchange® control valve disengages manually or automatically. Pressure then returns to the safe setting and enclosure power is energized by the EPCU. Loss of safe pressure causes the EPCU to deenergize power to the protected enclosure(s). All systems include form "C" contacts for audible or visual alarm systems.

Style Variances

STD (Standard) Style systems require manual operation of the Rapid Exchange® control valve. **SA (Semi-Automatic) Style** systems require manual engagement of the Rapid Exchange® control valve to initiate the exchange cycle, but automatically disengages the valve upon completion of the cycle. Loss of safe pressure requires an operator to manually restart both systems above. **FA (Fully Automatic) Style** systems engage and disengage the Rapid Exchange® control valve automatically, after an operator manually sets a safe pressure. In addition, FA Style systems restart automatically after a power or air pressure failure.

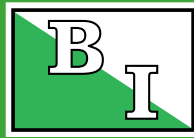

MODEL 2002
TYPE X

RAPID EXCHANGE® PURGING SYSTEM

EPS Division Technical Bulletin 2002-R1.1

08/96



STD Style
(Standard)



FA Style
(Fully Automatic)



CSA Approval applies to
Electrical Power Control
Unit Only

Standard Model Applications

Model Number: 2002 Type X
Designation: Purging System
Enclosure Volume: 15 Cubic Feet Maximum

***F.M. Approved**
Group B System
Available in
STD Style

STD (Standard) Style

UL & FM Approvals: Cl. I, Div. 1, Group C&D*
Rating Reduction: Division 1 to Unclassified

SA (Semi-Automatic) Style

UL & FM Approvals: Cl. I, Div. 1, Group C&D
Rating Reduction: Division 1 to Unclassified

FA (Fully Automatic) Style

UL & FM Approvals: Cl. I, Div. 1, Group C&D
Rating Reduction: Division 1 to Unclassified

Enclosure Protection Systems

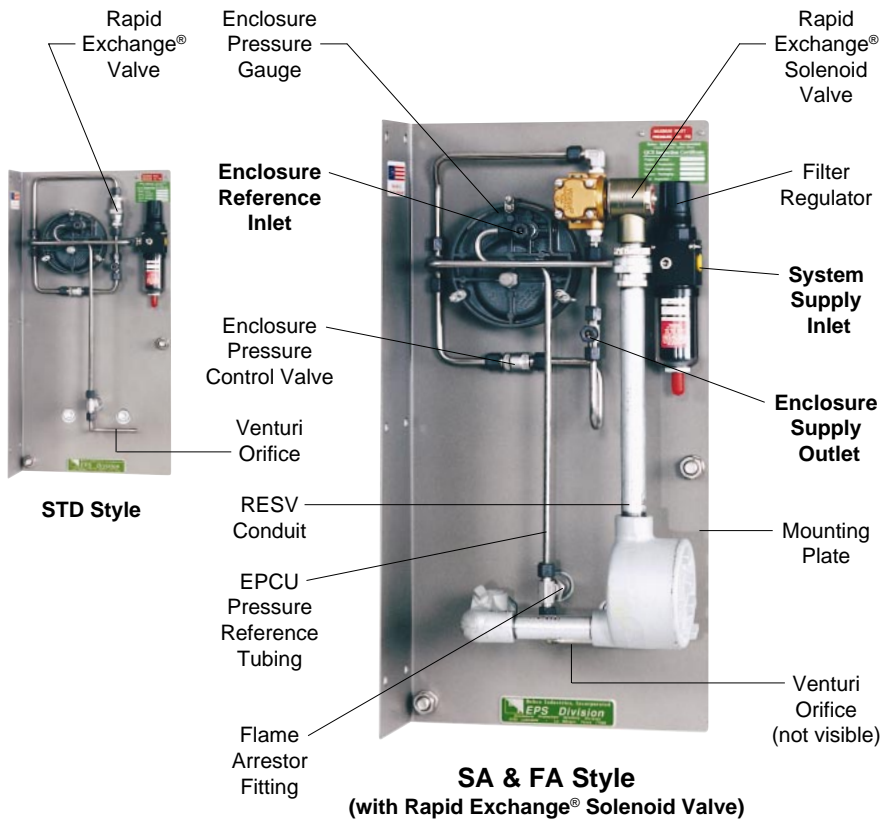

System Specifications

System Dimensions:	See Rear Cover
Shipping Weight (Lbs.):	STD - 45 / SA & FA - 47
Operating Temp. Range:	-20° F - 120° F
Supply Pressure Range:	80 - 120 PSI max.
Capacity & Filtration:	1.5 Oz. @ 20 Microns
Supply Requirements:	Clean Air or Inert Gas
Safe Press. Setpoint:	0.25" @ Safe Press.
Safe Press. Flowrate:	* 0.1 - 3.5 SCFH / Cubic Ft.
Exchange Pressure:	3" - 5"
Exchange Flowrate:	** 4 SCFM / 240 SCFH
Exchange Time:	1 Minute / Cubic Ft.
System Supply Port:	1/4" FPT
Enclosure Supply Fitting:	1/4" Tube Fitting
Enclosure Reference Fitting:	1/4" Tube Fitting
EPCU Conduit Port Size:	1/2" FPT
EPCU Power Requirements:	120 VAC 60 Hz 1Ø
(European 220 voltage only)	220 VAC 50 Hz 1Ø
(All voltage ratings are factory set)	*** 12-48 VDC
EPCU Power Consumption:	500 ma
Power Relay Contacts:	20 Amps @ 220 VAC
	20 Amps @ 28 VDC
	*** 20 Amps @ 48 VDC
Alarm Relay N.O. Contact:	20 Amps @ 220 VAC
	20 Amps @ 28 VDC
Alarm Relay N.C. Contact:	15 Amps @ 220 VAC
	10 Amps @ 28 VDC

* Enclosure integrity determines actual flow rate
 ** With regulator set to 60 PSI min. during exchange
 *** Optional 12-48 VDC Power Module Specifications

Material Specifications

Filter Regulator Body:	Zinc w/ Enamel Finish
Regulator Handle & Bowl:	Polycarbonate
Enclosure Pressure Gauge:	Alum. w/ Enamel Finish
Rapid Exchange Gauge:	Poly Case & Brass Tube
Rapid Exchange Solenoid:	Brass w/ Enamel Finish
Tube Fittings & Valves:	316 SS Forged Body
Tubing:	316 SS 1/4" .035 Welded
System Nameplates:	Silkscreened Lexan® & SS
Fastener Hardware:	SS Screws & Bolts
Mounting Plate:	316 14 Ga #3 Brush SS
EPCU Enclosure Body:	Bead Blast Cast Alum.
Conduit & Fittings (SA & FA):	Galvanized Steel
Enclosure Warning Nameplate:	Silkscreened SS

Lexan® is a registered trademark of the General Electric Corporation

EPCU Description

The Bebco 2000 Series EPCU is a factory programmed, field adjustable, microprocessor controlled unit featuring full status indication, redundant gate array logic and electromechanical relays. The EPCU is constructed from four major items - a power module, a pressure switch module, a logic module and a power mode selector switch. The sections are linked with polarized cable, and the boards are stacked in the EPCU enclosure on standoffs.

Basic EPCU Operation

When power is "off", the EPCU is at rest, alarm and power relays are deenergized, and the LED display is off. When power is switched "on", the EPCU performs a self-test of LED display and logic functions. The unit will then start-up. First, the unit must detect a safe (0.25") pressure to energize the alarm relay. The unit must then detect an exchange (2.0") pressure to initiate an exchange cycle time delay, which must terminate, uninterrupted by the loss of safe or exchange pressures, before the enclosure power relays energize. Loss of safe pressure causes the relays to deenergize (see power control options for more detailed information regarding EPCU operation).

CONSULT FACTORY FOR PANEL MOUNT SYSTEM INSTALLATION DETAILS

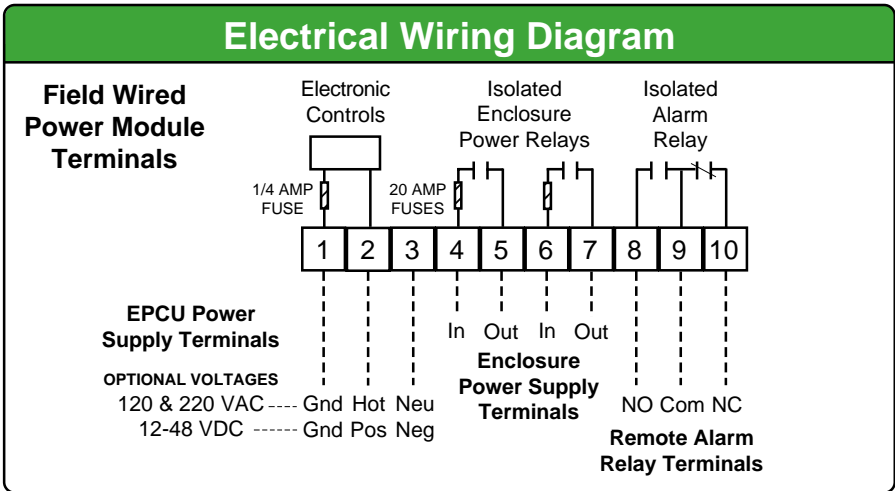
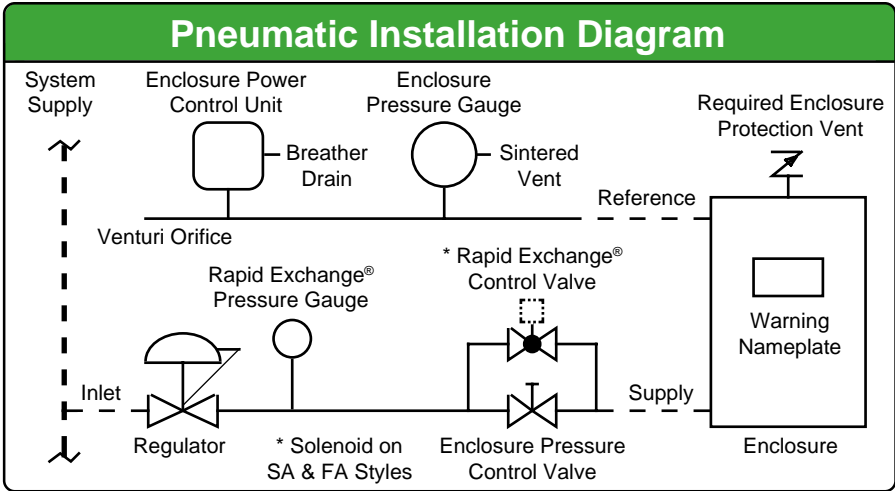

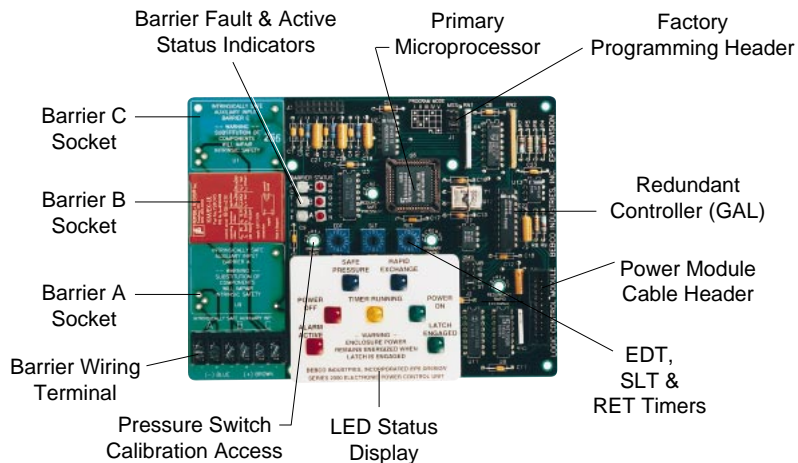

EPCU Logic Module

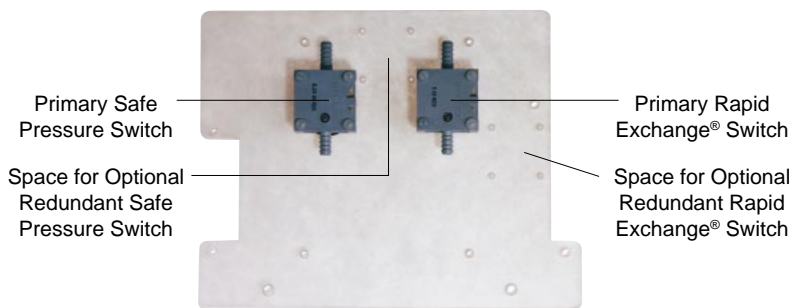

EPCU Pressure Switch Module

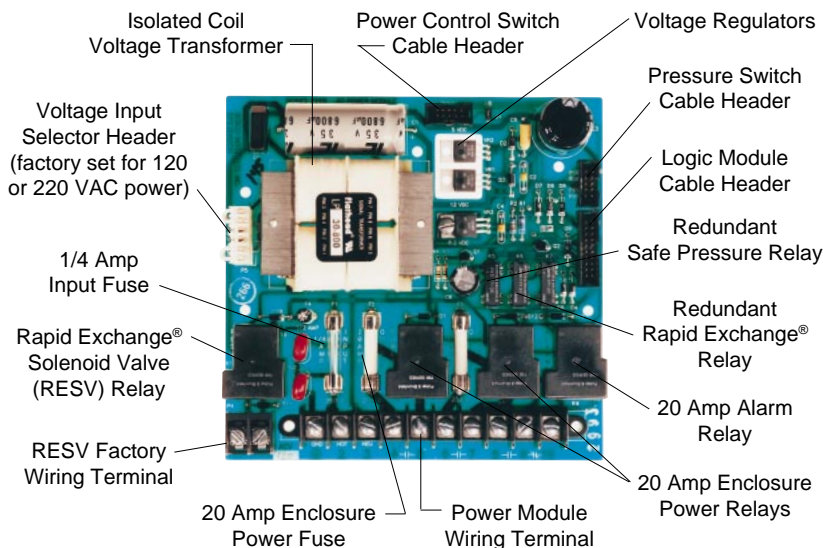

120/220 VAC EPCU Power Module

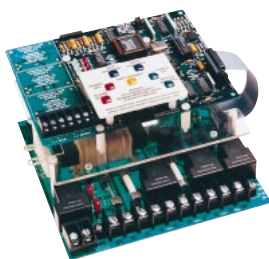

Assembled Electrical Power Control Unit

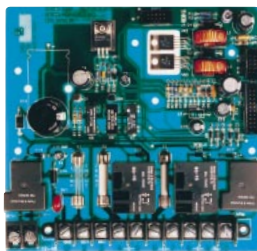

Optional 12-48 VDC EPCU Power Module

EPCU Features

LED DISPLAY INDICATORS

Power Off:	Enclosure Power Relays Deenergized
Power On:	Enclosure Power Relays Energized
Safe Pressure:	Enclosure Pressure > 0.15" w.c.
Rapid Exchange:	Enclosure Pressure > 2.0" w.c.
Timer Running:	Rapid Exchange® Timer Active
Alarm Active:	Enclosure Pressure < 0.15" w.c.
Bypass Engaged:	Control Bypass Active - CB & UB Modes
Latch Engaged:	Power Relay Latch Active - PL Mode

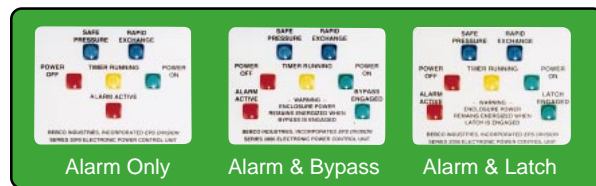

FIELD ADJUSTABLE TIMER FUNCTIONS

EDT (Exchange Delay Timer) (FA Style only) provides a time delay to prevent Rapid Exchange® solenoid valve from energizing until safe pressure can be stabilized.

SLT (Solenoid Latching Timer) (FA Style only) provides a time delay to keep the Rapid Exchange® solenoid valve energized until exchange pressure is detected. If the pressure is not detected, the EPCU will reset.

RET (Rapid Exchange Timer) provides a time delay after Rapid Exchange® pressure is detected, to allow four volume exchanges prior to energizing the enclosure power relays. If safe pressure or Rapid Exchange® pressure is lost or interrupted during time delay cycle, the EPCU will reset.

Power Control Options

NORMAL RUNNING (NR) MODE

EPCU features on-off push-button power control switch to activate control functions. Switch must be depressed to initiate start-up. After completion of start-up, safe pressure must be lost or switch must be depressed to deenergize enclosure power relays.

CONDITIONAL BYPASS (CB) MODE

EPCU features an off-on-bypass power control switch to activate control functions. Switch must be set to on position to initiate start-up. After enclosure power is energized, safe pressure must be lost or switch must be set to off position to deenergize enclosure power. After enclosure power is energized, switch may be set to bypass position, to temporarily latch enclosure power relays. A flashing LED then indicates bypass engaged, and the enclosure can then be accessed without deenergizing power (performed under specific conditions). Following access, safe pressure must be reestablished to resume normal operation. At that time, the switch may be reset to the on position, without disruption of enclosure power. Alarm relay normally deenergizes only upon loss of safe pressure, but can be programmed to deenergize when bypass is engaged, if specified at time of order.

UNCONDITIONAL BYPASS (UB) MODE *

Bypass position energizes enclosure power relays instantly by overriding EPCU controls, before or after power is energized safely. In addition, alarm relay deenergizes when unconditional bypass is engaged, regardless of safe pressure status.

POWER LATCHING (PL) MODE *

EPCU features push-button switch and latches enclosure power relays after completion of a safe start-up. Enclosure power relays then remain energized regardless of any condition, including loss of safe pressure and complete EPCU logic module failure. When safe pressure is lost, the power relays remain energized, the alarm relay deenergizes and a flashing LED indicates that the latch is engaged, until safe pressure is restored. Power control switch must be depressed to deenergize enclosure power.

*** UB & PL MODES ARE NOT THIRD PARTY APPROVED AND ARE ONLY INTENDED FOR SPECIAL APPLICATIONS**

Model 2002 System Accessories

CONNECTION FITTINGS

NC-4	1/4" Ninety Connector
SC-4	1/4" Straight Connector
EFC-4	1/4" Flush Connector
EBC-4	1/4" Bulkhead Connector
EPC-12	3/4" Pipe Connector

ADDITIONAL ITEMS

SMK-2, -3 or -10	System Mounting Kit
RAH	Remote Alarm Horn
RAB-1	Div. 1 Remote Alarm Beacon
LCK	L Fitting Conduit Kit
TCK	T Fitting Conduit Kit
PIAD	Purgeable Instrument Access Door
SRM-2000	Switch Resistor Module
PD-2000	Proximity Detector

INSTALLATION & OPERATION MANUAL

2002-IOM Installation & Operation Manual

ENCLOSURE PROTECTION VENTS

ONE VENT REQUIRED WITH EACH SYSTEM

EPV-2-SA-00	Straight w/ Spark Arrestor
EPV-2-SA-90	Rt Angle w/ Spark Arrestor

WARNING NAMEPLATES

EWN-1	Class I Enclosure Warning
ETW	Enclosure Temperature Warning

FACTORY INSTALLED ACCESSORIES

DCPM-2.0	12-48 VDC Power Module
ISB-A	Channel A Barrier
ISB-B	Channel B Barrier
ISB-C	Channel C Barrier
RSPS	Redundant Safe Pressure Switch
RRES	Redundant Rapid Exchange Switch
KLA	Power Switch Key Lock Assembly

ONE (1) ENCLOSURE WARNING NAMEPLATE & ONE (1) INSTALLATION & OPERATION MANUAL IS PROVIDED WITH EACH SYSTEM

Model Number Designations

2002 - STD - CI - NR - LH

Series Model Number

System Style

STD - Standard

SA - Semi-Automatic

FA - Fully Automatic

Area Classification

CI - Class I, Group C & D Area

IB - Class I, Group B Area (STD Only)

Power Control Mode

NR - Normal Running

CB - Conditional Bypass

UB - Unconditional Bypass

PL - Power Latching

Mounting Configuration

LH - left hand left side of enclosure

RH - right hand right side of enclosure

TM - top mount top of enclosure

BM - bottom mount bottom of enclosure

WM - wall mount wall surface

FM* - frame mount external frame or rack

PM* - panel mount enclosure surface cutout

* FM & PM Configurations feature flush mount EPCU
Flush mount EPCU is not suitable for Group B Area

OPTIONAL INTRINSIC SAFETY BARRIERS

DESCRIPTION & OPERATION

The EPCU Logic Module can accommodate up to three intrinsic safety barriers, to interact with remote devices and affect operation of the EPCU. The barriers are installed and programmed by the factory at time of order, and they are designed to function either in conjunction with a customer furnished switch and a Bebcu furnished resistor network cable, or a Bebcu furnished proximity detector. Each barrier develops a low power signal, to create a two wire closed loop circuit. Operational status of each barrier is indicated by a green LED to show active (closed switch) status, and by a red LED to show faulted (line breakage) cable status. All barriers can be reprogrammed to duplicate other barrier functions as required, upon specific request.

BARRIER PROGRAMMING OPTIONS

Barrier A Function - when switch opens

Disables start-up & Rapid Exchange® cycle
Deenergizes enclosure power and alarm relay
Functions parallel to safe pressure switch

Barrier B Function - when switch opens

Disables Rapid Exchange® cycle
Functions parallel to Rapid Exchange® switch

Barrier C Function - when switch closes

Energizes Rapid Exchange® solenoid valve

Overall System Dimensions

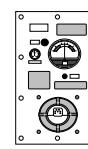
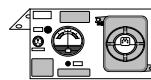
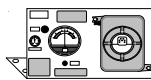
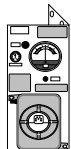

STD / SA & FA	LH - left hand	RH - right hand	TM - top mount	BM - bottom mount	WM - wall mount	FM or PM - flat panel
Height	22	22	12	12	22	24
Width	11	11	23	23	11	13
Depth	10.75 / 13.75	10.75 / 13.75	10.75 / 13.75	10.75 / 13.75	12.50 / 14.50	11.50 / 14.50

Dimensions in inches. Mounting dimensions available upon request. FM & PM panel cutout dimensions: 23h x 12w

Height & Width dimensions reflect mounting plate measurements. Depth dimension reflects overall measurement of system, including components.

Simplified EPCU Redundant Logic Diagram

OPERATION

Signal (1), from SPS is sent to μ P, GAL and SPCR coil. Signal (2) from RES is sent to μ P and GAL. During start-up, GAL verifies all μ P functions. GAL & μ P must receive uninterrupted signals from SPS and RES to prevent logic resetting. After GAL verifies all start-up procedures, it sends "power enabled" Signal (3) to PER coil. Then, μ P sends "power request" Signal (4) through the SPCR and PER contacts to EPR coils.

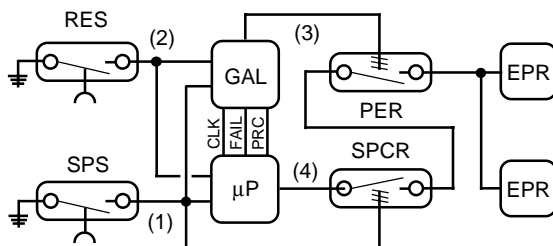

RES - RAPID EXCHANGE® SWITCH
SPS - SAFE PRESSURE SWITCH
GAL - GATE ARRAY LOGIC
 μ P - MICROPROCESSOR
PER - POWER ENABLED RELAY
SPCR - SAFE PRESSURE CONFIRMATION RELAY
EPR - ENCLOSURE POWER RELAY

Local Sales Representative

IMPORTANT NOTES

All specifications subject to change without notice.
Warranty & Liability policies available upon request.
One (1) Enclosure Protection Vent must be purchased with each system specified above, at time of order.