

Description

The 6000 series Type X, EEx 'px' purge pressurization system protects general-purpose equipment mounted in a standard enclosure so that it can be located and operated in a hazardous area. The hazardous area classification can be Class I and/or Class II, Division 1/Zone 1 and/or Zone 21. The 6000 series operates by controlling and monitoring compressed instrument air or inert gas through the protected enclosure(s) to remove and prevent the accumulation of flammable gas, vapors, or dust.

The 6000 series system features these main parts:

- Electronic processor (EPCU) housed in an explosion/ flameproof enclosure
- Intrinsically safe electrical/pneumatic manifold assembly
- Input/output connections and controls for operation
- I.S. user interface for programming and monitoring the system
- 316L stainless steel type 4X enclosure for EPCU and connections
- Pressure relief vent with flow and pressure monitoring at the exhaust

The user interface allows programming of up to 4 switch inputs, temperature modules, enclosure power contacts, 2 auxiliary outputs, and various operational functions. Also, the user interface screen allows monitoring and easy setup of configurable variables. With the user interface menus, configuration of the standard information for setup and operation of a system such as purge time, flow rates, pressures, and enclosure size are easily programmable. Additional features allow Class I and Class II operation, inputs for system bypass, enclosure power on/off, temperature overload and activation of Rapid Exchange flow for cooling or auxiliary relay for separate cooling source, delay power shutdown, and much more. The two auxiliary contact outputs can be configured to activate on most of the input switches or any of the configured alarm states for pressure, flows, and temperature.

The power for the solenoid valve on the manifold unit, inputs, and EPV-6000 vent are provided by the EPCU through the internal, galvanically isolated intrinsic barrier. No additional intrinsic safety barriers are required for annunciation.

The adjustable mounting brackets and the universally mounted vent make the 6000 system easy to install horizontally or vertically onto the enclosure. Component kits are available at a cost savings for custom installation requirements.

The 6000 series provides a complete system for purging and pressurizing enclosures for hazardous location operation.

The 6000 series system can be set up for Class I/ Division 1 (Zone 1), Class II/Division 1 (Zone 21), or both Class I & Class II/Division 1 (Zone 1 & Zone 21) applications in accordance with the NEC-NFPA 70, NFPA496, ISA 12.4, IEC61241-4, and EN60079-2. This system also complies with IEC61508, SIL 2 level of integrity with SIL 3 option available.

6000 Series

Class I & Class II, ($\leq 450 \text{ ft}^3$) Zone I & Zone 21 (12.7 m^3)



Model EPV-6000-AA-01



Model 6000-DV-S2-UN-WH-AC

Component Kit (model 6000-DV-S2-UN-CF-AC)



Control unit w/ Ex enclosure



User-interface



Manifold with solenoid



Standard Model Applications

Model Numbers:	6000 Type X & Ex px
Designation:	Rapid Exchange® Purging Systems
Model 6000 Enclosure Volume:	450 ft ³ / 12.7m ³ max.
EX approvals:	Ex II 2GD EEx px, ib, de, d, IIC, Demko ATEX to the EN60079-2 for gas, IEC61241-4 for dust, designated Ex px
cULus:	Type X, Class I / Division 1 / Groups A-D, Class II / Division 1 / Groups E, F, & G to the NFPA 496
Safety Integrity Level:	IEC 61508, SIL 2. SIL 3 option available

6000
SERIES

Type X & Ex [px]

Series 6000 Identification of Components

6000
SERIES

Type X & Ex [px]

6000 Control Unit

Easy connection to protective gas supply

Manifold for purging and pressurization

Type 4X (IP66) fittings for flow

User interface module for easy programming with display

316L stainless steel Type 4x (IP66) ratings

Brackets for easy mounting to enclosure

3/4" conduit for power connections, easy to add poured seals

Cable glands for I.S. inputs/outputs

EPV-6000 Vent

Movable vent cap

Mounts on vertical or horizontal surface of enclosure

Spark arrestor

1 1/2" NPT knockout with seal lock nut

Connector for I.S. connection back to control unit

Exploded View

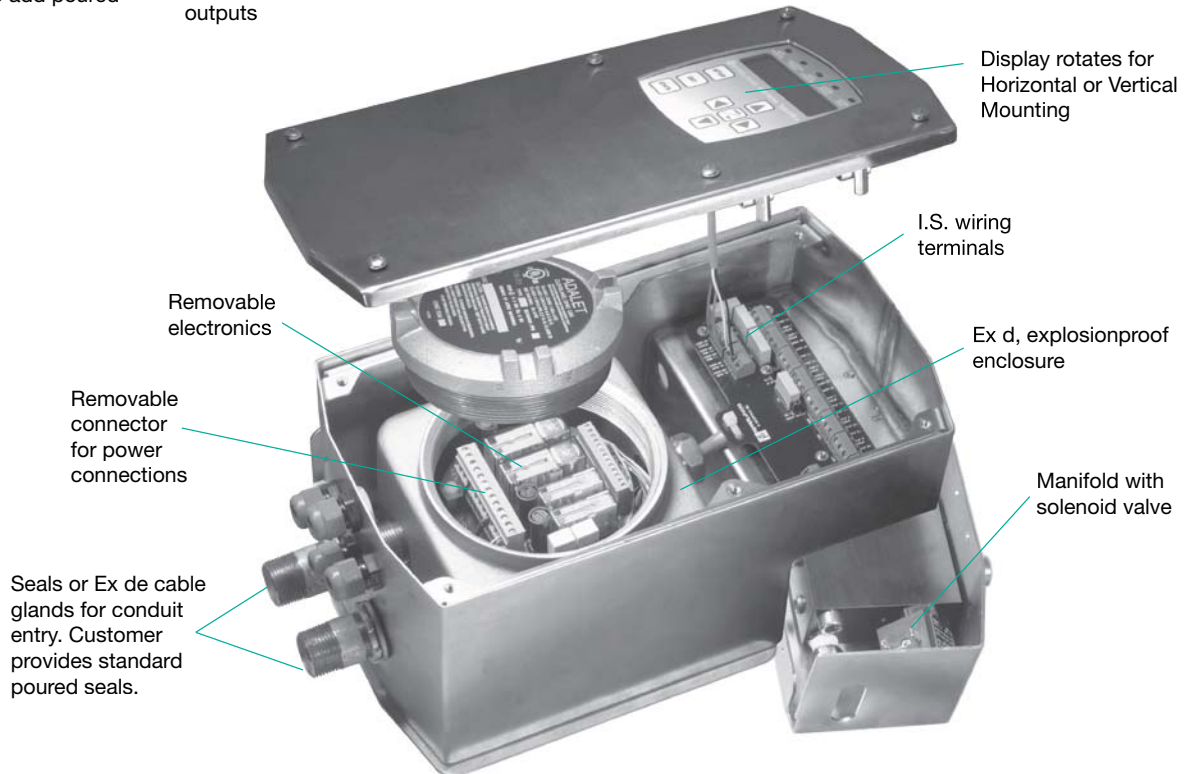

Series 6000 Component Kit

User-Interface w/cable and V31 connector

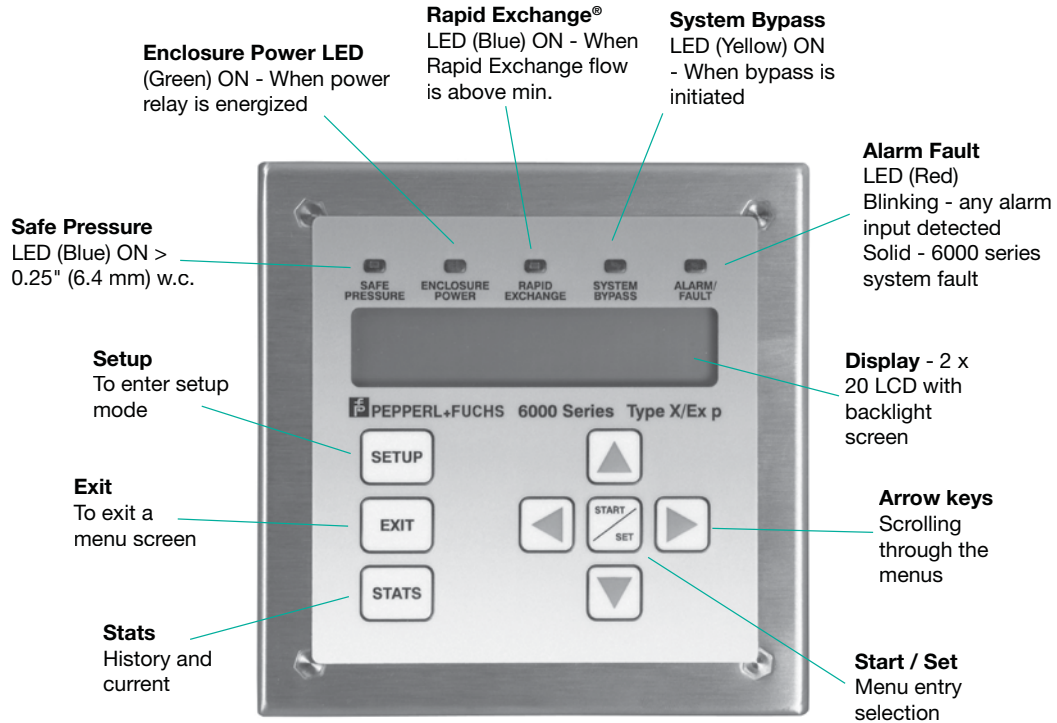

Control unit and explosion / flameproof enclosure



Optional pneumatic manifold w/solenoid



6000 SERIES

Type X & Ex [px]

Rapid Exchange® is a Registered Trademark of Pepperl+Fuchs Inc.

Operation of 6000 series

The 6000 series consists of the control unit and user interface mounted in a 316L stainless steel Type 4X (IP66) enclosure with the pneumatic solenoid valve mounted on the unit. A proportional valve can be ordered in place of the solenoid valve for continuous control of flow and pressure to the enclosure. The EPV-6000 series relief vent is separate and is mounted to the enclosure. The 6000 series control unit is also available in a kit form that consists of the key components of the system, the control unit, and the user interface. It does not include the enclosure and manifold. The user interface includes a panel-mount bracket so that it can be panel mounted to the customer's enclosure. The pneumatic valve for the protective gas can be supplied by the customer, or the 6000 series manifold or proportional valve can be purchased separately. The EPV-6000 relief vent is still required.

The components of the 6000 series control unit are listed below:

- EPCU mounted in an explosion/flameproof enclosure
- I.S. user-interface with display and cable
- I.S. termination board (does not come with 'CK' kit version)
- Manifold with I.S. solenoid valve (does not come with 'CK' kit version)
- Flush mount type 4X IP66 fitting for protective gas supply to enclosure with tube attached
- Type 4X cable glands for I.S. wiring to I.S. inputs, vents, and temperature modules
- 316L stainless steel pipe nipples for power wires
- 316L stainless steel type 4X enclosure for the 6000 series controller

The components of the EPV-6000 vent:

- EPV-6000 vent with spark arrestor screen
- 1½" sealing nut with gasket for attachment of vent to customer's enclosure
- A 5 meter, quick disconnect cable; blue (denoting I.S.), for connection to I.S. termination board inside 6000 series control unit

The 6000 series control unit and vent can be universally mounted to the customer enclosure. Top, bottom, right-, or left-side mounting can be completed with only one control unit and vent. Mounting configuration does not need to be designated when ordering. One unit is used for enclosure sizes up to 450 ft³ (12.7 m³).

Electronic Power Control Unit – EPCU

The EPCU houses the redundant microprocessors, enclosure power contacts, (2) auxiliary contacts, power supply module, galvanically isolated barriers for the inputs, vent(s), and temperature modules; all stackable and easy to remove and install into the explosionproof enclosure that houses them. The power supply module is available in 24 VDC or 100-240 VAC units. The enclosure power contacts are forced-guided safety relays. The auxiliary contacts can be user configured for different functions depending on user requirements.

User-Interface Controller - UIC

The 6000 series is user programmable for many of the configurable options available. This is done with the intrinsically safe user-interface on the face of the unit, which can also be remote mounted. The user-interface is a 2 x 20 LCD that is programmed through a set of buttons on the menu driven unit. All configuration and options are programmed through this unit. There are also (5) LEDs for easy visual indication of operation:

- Safe Pressure – This turns on (blue) when safe pressure is achieved inside the enclosure.
- Enclosure power – This is (red) when the enclosure power is off, and (green) when enclosure power is on. The enclosure power can be on only after a successful purge and a safe pressure is achieved. Bypass option allows power to remain on if safe pressure is lost.
- Rapid Exchange® – The Rapid Exchange or purging flow rate turns on (blue) when the flow rate is measuring proper flow.
- System Bypass – This turns on (yellow) when the system bypass is active. This should be used only when the area around the enclosure is known to be safe.
- Alarm Fault – The (red) LED blinks when any alarm input is detected and is solid when there is an internal system fault.

Pneumatic Manifold with I.S. Solenoid

- Manifold with I.S. solenoid valve: The manifold system is mounted on the 6000 control unit providing a needle valve to set enclosure pressure and an I.S. solenoid valve that is used for purging (Rapid Exchange). Power for the I.S. solenoid valve is provided by the EPCU and is galvanically isolated. Regulated instrument-grade air or nitrogen is required.
- Proportional valve option: The I.S. proportional valve is separated on the 6000 control unit and provides continuous flow and pressure to the enclosure for purging (Rapid Exchange) and pressurization. Power for the I.S. solenoid valve is provided by the EPCU and is galvanically isolated. No needle valve is required. Pressures can be controlled from a user set point.

The 6000 series unit can be ordered without the manifold or proportional valve so that customers can use their own method or valves for purging and pressurization. If a third-party electronic valve is used, the valve must be certified and installed in accordance with the hazardous location where it is operating. The use of the 6000 series manifold unit allows easy and correct installation of the system.

Requirements for Purging/Pressurization

Certifications allow the 6000 series to be used on enclosures in a gas, dust, or both gas and dust hazardous atmospheres. Gas atmospheres require the purging of the enclosure. Dust atmospheres require the physical removal of all the dust that collects inside. Both gas and dust atmospheres require the following: 1) removing the dust, 2) sealing the enclosure, and then 3) purging the enclosure.

After these sequences, the pressure within the enclosure is above the minimum level. The equipment within the enclosure can be energized.

Operation of 6000 series

Purge Timing

When using the 6000 series in a gas or gas and dust location, the time for purging an enclosure can be based either on a known purge rate and time (fixed purge time), or based on the flow rate being measured from the vent (dynamic purge time). Both methods base the time on the flow measurement at the vent, and complete the process in steps. The EPCU will take the readings from the vent and use the appropriate reading (listed below) as the useable flow rate. For example, if the flow rate measurement from the EPV-6000 vent is 7 SCFM, the EPCU will use 5 SCFM as the flow rate for evaluation. The flow rate measurement steps and corresponding enclosure pressures are as follows:

- 5 SCFM @ 1.3" w.c. , (141 l/min @ 33 mm w.c.)
- 12 SCFM @ 2.5" w.c., (340 l/min @ 64 mm w.c.)
- 20 SCFM @ 3.1" w.c., (565 l/min @ 77 mm w.c.)
- 30 SCFM @ 3.4" w.c., (850 l/min @ 86 mm w.c.)

Fixed Purge Time

If the purge time must be held to a specific time, then this time is based on the known enclosure volume, number of volume exchanges, and flow rate through the vent. If the flow rate is below the required minimum, then the purging cycle will reset and will not start until the flow rate is above the selected rate. This set up does not allow purge flow to go below the value required and will not recalculate the time for purging if it goes above the required purge rate. This measurement method is the same type as was used in our previous system, the 4000 series.

Dynamic Purge Time

Dynamic purge time allows the purge time to be updated to the purge flow through the vent. This method is not dependent on a constant flow from the protective gas source. It bases the purge time on the measured flow and not a set flow. This is very useful when the protective gas supply pressure varies throughout the purging cycle or when it may vary from one installation to another.

The following parameters must be entered for the dynamic purge time:

- Enclosure volume
- Number of exchanges

The purge time will be based on the measurement of the vent and evaluation of this measurement from the EPCU. This allows recalculation of the time based on this measurement. During the dynamic purge time, the user-interface will display the purge time in a percentage starting with 0% and ending with 100% (purge time complete).

Purging Modes

Purging start-up can be set up in 4 different modes, which are explained below:

- STD – Standard mode requires the operator to engage the manifold solenoid valve manually when purging and manually disengage when a successful purging is complete.
- SA – Semiautomatic mode requires the operator to engage the manifold solenoid valve manually when purging. The EPCU will automatically disengage when a successful purging is complete.

- FA – Fully-automatic mode will automatically engage the manifold solenoid valve when safe pressure is detected and will automatically disengage when a successful purging is complete.
- PV –The proportional mode will continuously control the flow rate during and after purging. This allows maximum efficiency of the protective gas supply. This is very useful for areas where there is a limited amount of the protective gas supply available.

Inputs

There are (4) intrinsic safety inputs for activation of various outputs and actions by the EPCU. These inputs accept only a dry contact for activation and are supplied by the EPCU's galvanically isolated barrier. The assignments of the inputs for various actions are achieved through the user-interface controller. Only one function can operate an input. These inputs can bypass the system for live maintenance on the enclosure. The intrinsic safety inputs activate the auxiliary relays, energize the Rapid Exchange valve, de-energize the enclosure contacts, and shut the system down, in addition to many more actions and outputs.

Outputs

There are (2) normally open dry contacts for the enclosure power that can be energized only after a successful purging and a minimum enclosure pressure is maintained. Loss of pressure will cause the contacts to de-energize unless the shutdown timer is active or bypass mode is implemented. Also available are the Auxiliary 1 and Auxiliary 2, SPDT dry contact outputs. The auxiliary outputs can be user configured using the user-interface controller and are controlled by various inputs or various conditions such as low pressure, loss of pressure, bypass implemented, Rapid Exchange valve on, enclosure above maximum pressure setting, and many more. Both enclosure contacts and auxiliary contacts are forced-guided safety relays for functional safety.

EPV-6000 I.S. Relief Vent

The EPV-6000 vent exhausts excess pressure from the enclosure if the pressure within the enclosure is above 1.0" w.c. and measures flow and pressure during operation. The 6000 series vent has a pressure transducer and thermal flow sensor that is connected to the 6000 EPCU and is intrinsically safe through the galvanic isolation barrier within the EPCU. Because measurement of the flow is always at the exhaust of the pressurized enclosure, the vent is located on the enclosure(s) such that it is venting to the atmosphere.

The vent is connected to the I.S. termination board using the V1 connector and cable that comes with the vent. The EPV-6000 vent can be mounted vertically or horizontally and is not gravity dependent. For corrosive environments, the EPV-6000 has an optional stainless steel cap so that the body of the vent is mounted in the enclosure with just the stainless steel cap exposed to the outside environment.

Electrical Wiring Diagrams

The I.S. termination board is mounted inside the Type 4X (IP66) stainless steel enclosure and does not require any lead seals to the EPCU enclosure. Wiring from the EPCU to this I.S. termination board is provided.

The power connection for enclosure power, auxiliary outputs and power to the EPCU is completed within the explosionproof enclosure that houses the EPCU. A stainless steel 3/4" conduit extends to the outside of the Type 4X, IP66 stainless steel enclosure for easy connection of the lead seals. Lead seals or Ex de cable glands are not provided, but are available as an option. Any certified lead seal or Ex de cable glands can be used. No special seals are required.

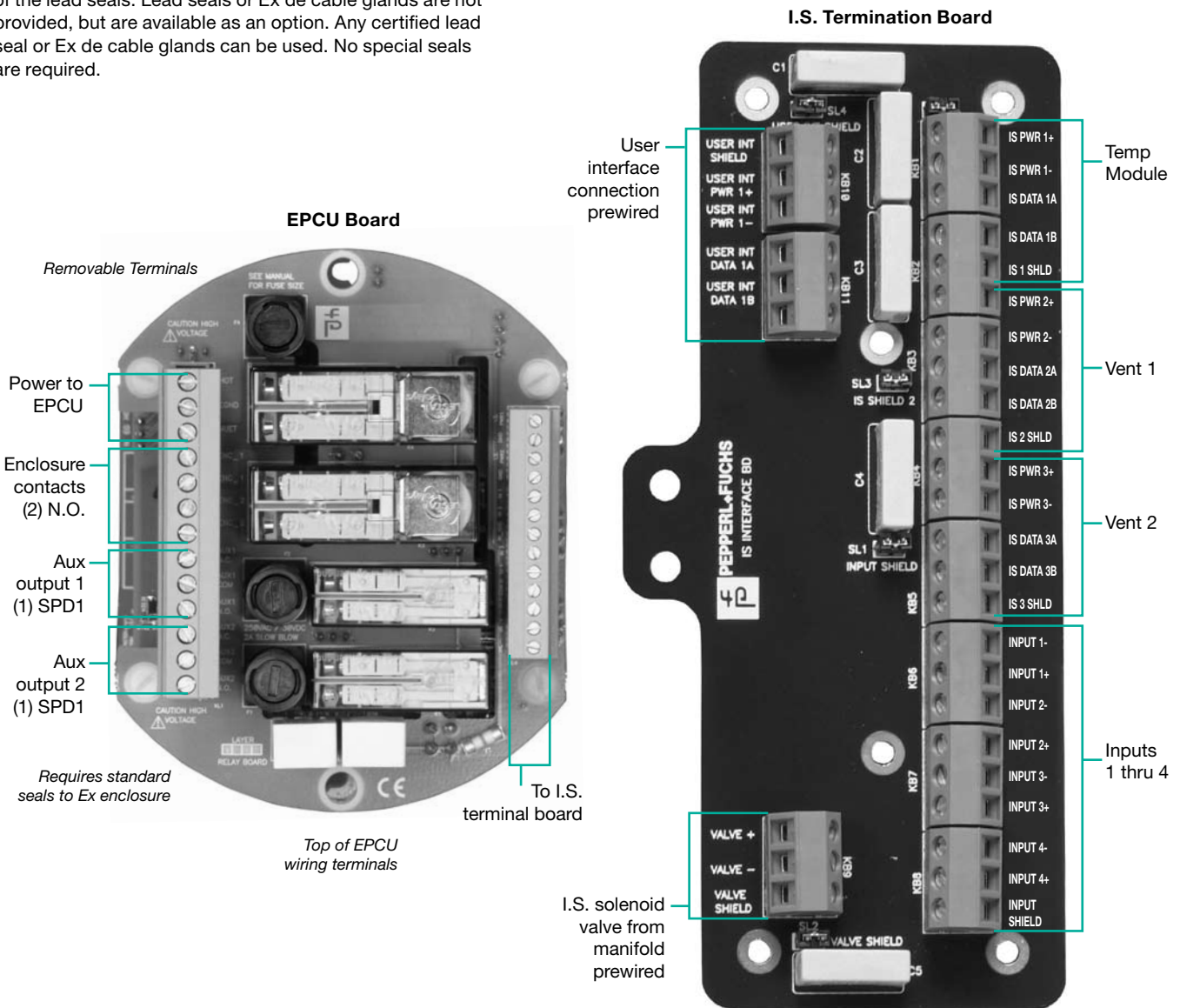

Pneumatic Diagram

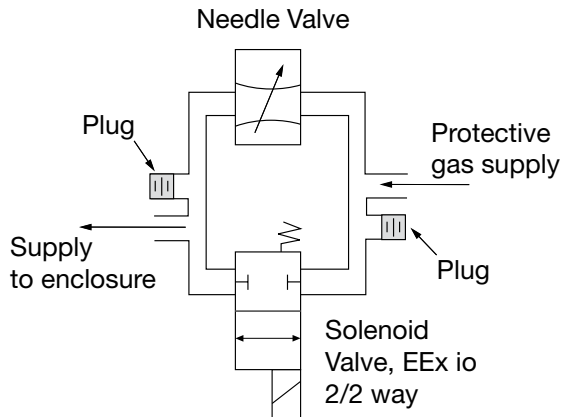

Dimensions (in)

6000 Control unit with housing

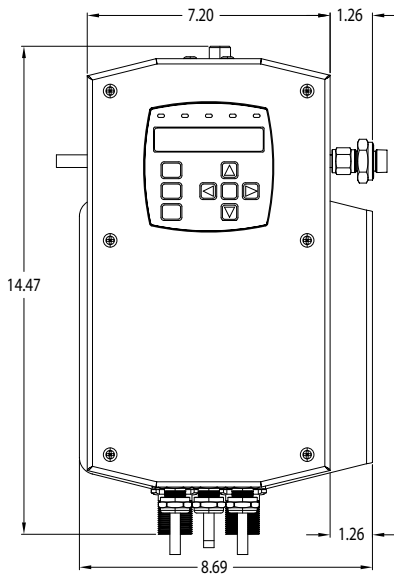

Model 6000 System Accessories

Connection Fittings

- US-EXDE-3/4
- LCK, TCK
- EFC-6-SS (included with unit)
- CG-8
- Ex de cable gland
- Conduit fitting kits
- Flush mount connector
- Cable gland

Additional Items

- HR-SW00
- HR-SW01
- US-B75-02-WJC
- SMK-6000
- SMK-6000-CK
- 6000-RUI-KIT-00
- 6000-MAN-DV-01
- 6000-MAN-PV-01
- Key switch (removable in one position)
- Pushbutton switch (on/off)
- 3/8" filter regulator (40 micron filter)
- Mounting bolts and hardware
- Mounting bolts and hardware for component kit
- Kit for remote mounting user-interface unit
- Manifold w/ I.S. solenoid valve
- I.S. proportional valve

Warning Nameplates - (1) EWN tag comes with every system ordered

- EWN-1G
- EWN-2D
- EWN-1/2GD
- ETW-15
- Class I, Zone 1 warning metal tag
- Class II, Zone 21 warning metal tag
- Class I & II, Zone 1 & 21 warning metal tag
- Temperature warning metal tag

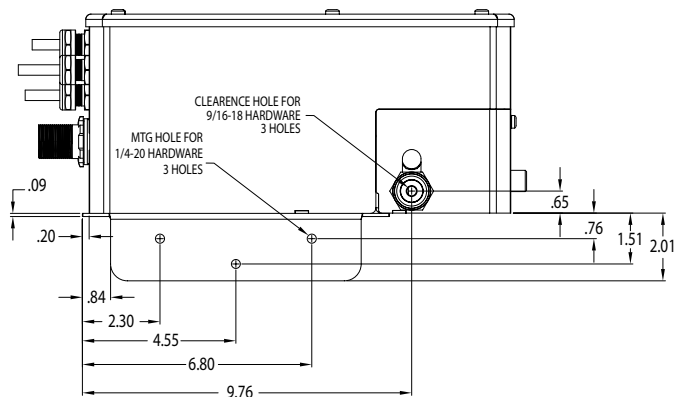
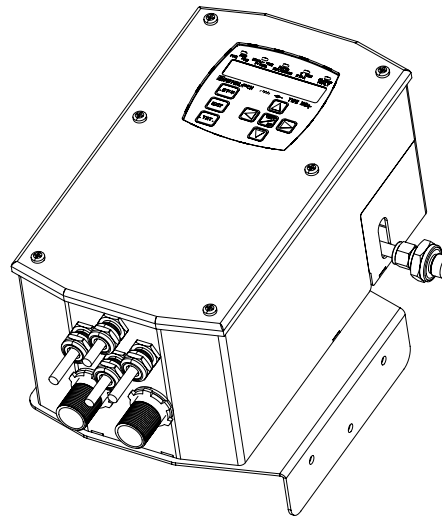
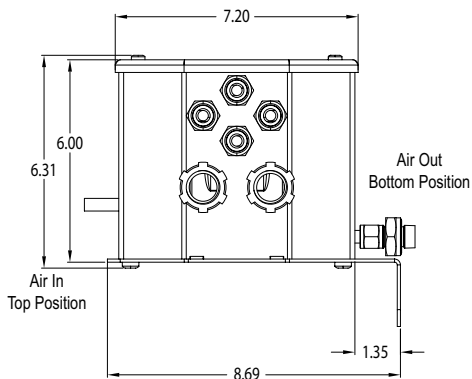

6000 SERIES

Type X & Ex [px]



4421 Tradition Trail Plano TX 75093
(972) 964 - 2700 or (800) 836 - 7472 • Fax: (972) 964 - 2755
Web www.isccompressedair.com • Email: iscinfo@iscsales.com

Dimensions (in)

Type X & Ex [px]

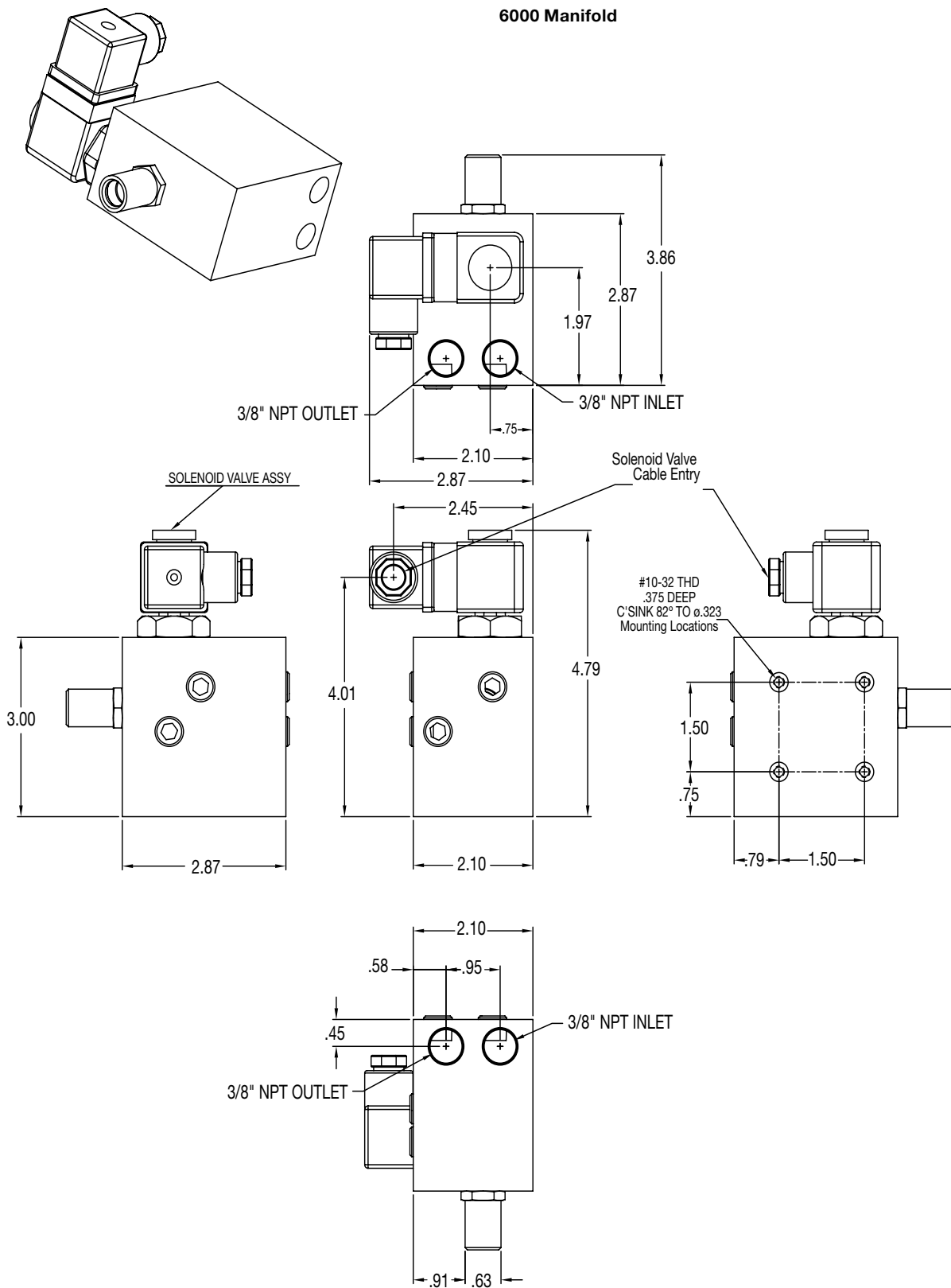

General Specifications

Enclosure Volume:	450 ft ³ (12.7 m ³)
Number of volume exchange:	4 to 19
Hazardous environment:	Gas, Dust, Gas + Dust
Operation mode for Purging (Rapid Exchange valve)	
STD	Manually engage and disengage
SA	Manually engage, automatically disengage
FA	Automatically engage and disengage

Electrical Parameters

6000 Series control unit

Power requirement:	
AC Version:	100 to 255 VAC/ 50-60Hz / 100 mA
DC Version:	20 to 30VDC / 600 mA
Outputs:	
Enclosure contact output:	8 A @ 240 VAC
(Dry contacts (2) SPST N.O.)	1 A @ 24 VDC
Auxiliary 1 contact output:	
(Dry contacts, SPDT)	2 A @ 240 VAC 0.5 A @ 24 VDC
Auxiliary 2 contact outputs:	
(Dry contacts, SPDT)	2 A @ 240 VAC 0.5 A @ 24 VDC
Inputs:	
Contact inputs 1,2,3,4:	2.5 VDC @ 2 mA, I.S.
Temperature inputs:	6000-TEMP-..., I.S.
Vent(s) EPV6000:	I.S. connection via connector Up to 2 vents can be connected
User Interface module:	
	I.S. connection via M8 (V31) provided LCD for menu driven set-up and operation
LED indication	
Safe Pressure:	BLUE – Safe pressure is achieved
Enclosure Power:	GREEN- power on, RED – power off
Rapid Exchange:	BLUE – when purging is running
System Bypass:	YELLOW – when bypass is activated
Alarm Fault:	RED blinking - any alarm input detected RED solid – 6000 series system fault

Pneumatic Parameters

Protective gas requirement:	Instrument grade air or inert gas
Pressure requirement:	20 to 120 psig (Filter + Regulator not provided)
Safe pressure minimum:	
Gas:	0.25" w.c. (6.4 mm w.c.)
Dust:	0.65" w.c. (16.5 mm w.c.)
Gas+Dust:	0.65" w.c. (16.5 mm w.c.)
Purging flow rate increment and enclosure pressures at flow rate:	
	• 5 SCFM @ 1.3" w.c. , (141 l/min @ 33 mm w.c.)
	• 12 SCFM @ 2.5" w.c., (340 l/min @ 64 mm w.c.)
	• 20 SCFM @ 3.1" w.c., (565 l/min @ 77 mm w.c.)
	• 30 SCFM @ 3.4" w.c., (850 l/min @ 86 mm w.c.)
Flow rate (pressurization):	0.01 SCFM (0.30 l/min) and up
(depends on enclosure seal)	
Inlet fitting to Manifold:	3/8" NPT female
Outlet fitting from Manifold:	3/8" bulkhead fitting provided

Operation Conditions

Storage Temp:	-40 °F to +190 °F (-40 °C to +90 °C)
Operating Temp:	6000 Control unit: -4 °F to +140 °F (-20 °C to +60 °C)
EPV6000 vent:	-4 °F to +140 °F (-20 °C to +60 °C)

Mechanical Specifications

6000 Control unit

Protection class (for all electronics):	Type 4X, IP66
Weight:	25 lb
Power Connections:	¾" NPT male pipe (explosion proof seals required)
I.S. Input connections:	Terminal connection inside 6000 series unit
Material:	
Enclosure:	316L (UNS31603) Stainless Steel
Manifold valve:	Anodized 6082 Aluminum
Fittings:	316L (UNS31603) Stainless Steel

EPV6000 Relief Vent

Flow rate measurement	Flow rate is measured in increments, 5, 12, 20, 30 SCFM, (141 l/min, 340 l/min, 565 l/min, 850 l/min)
Protection Class:	Mounting fitting Type 4X, IP66
Weight:	2lb
Power connections:	M12 (V1) pin connector (mating connector with cable comes with vent for connection to the control unit); Intrinsically safe
Mounting:	Mounting can be any orientation to the enclosure Not dependent on gravity
Mounting hole:	1 ½" NPT knockout hole, mounting with sealed nut
Material:	
EPV-6000-AA:	6063 T6 Aluminum
EPV-6000-SS:	303 (UNS30300) stainless Steel cap
Spark arrestor assembly:	Protected with 304 (UNS31603) Stainless Steel Screen Movable so that opening can be positioned downwards

Model Number Designations

	Control Unit	6000 - DV - S2 - UN - WH - AC
Valve Type		
DV	- digital solenoid valve	
PV	- proportional valve	
NV	- no valve	
Safety Integrity Level		
S2	- Sil 2, IEC61508, standard	
S2	- Sil 3, IEC61508	
Connection Style		
WH	- with stainless steel housing	
CK	- component kit	
XD	- w/Ex de cable glands	
Power Supply		
AC	- 95-220 VAC	
DC	- 24 VDC	
	Vent	EPV - 6000 - AA - 1
Body Type		
AA	- anodized aluminum std.	
SS	- stainless steel cap	