

OPTIONAL 2" PLEATED FILTER. SLIDING FRAME ONLY.

DIGITAL TEMPERATURE CONTROLLER

EASY MOUNT FLANGE ASSISTS ONE-MAN INSTALLATION; UNIT INITIALLY HUNG ON AIR FLOW OPENING

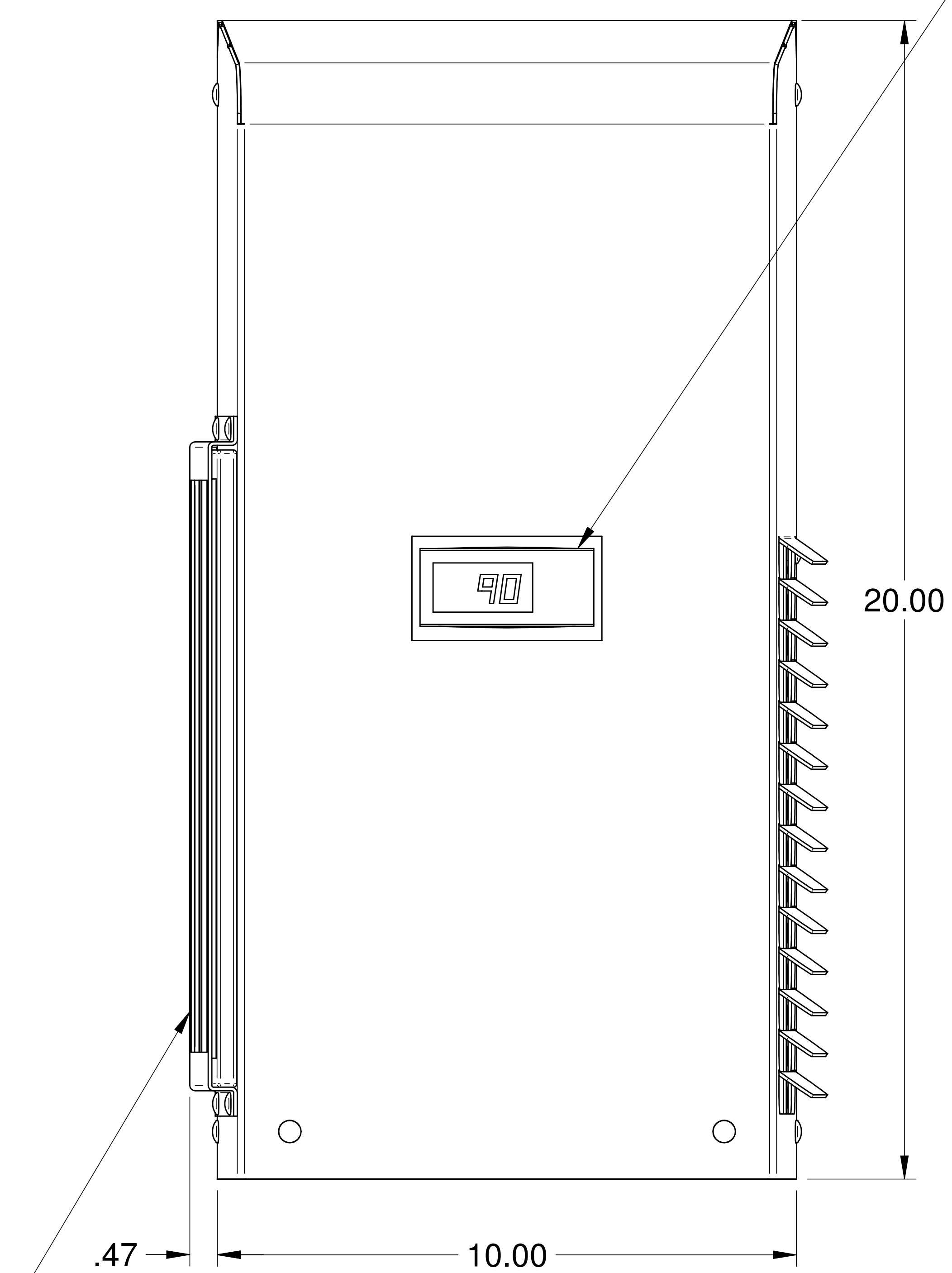

AMBIENT AIR IN. REUSABLE FILTER. OPTIONAL FRAME:

- 1) SECURITY FRAME STANDARD ON STAINLESS STEEL
- 2) SLIDING FRAME STANDARD ON PAINTED
- 3) OPTIONAL 2" FILTER WITH SLIDING FRAME ONLY

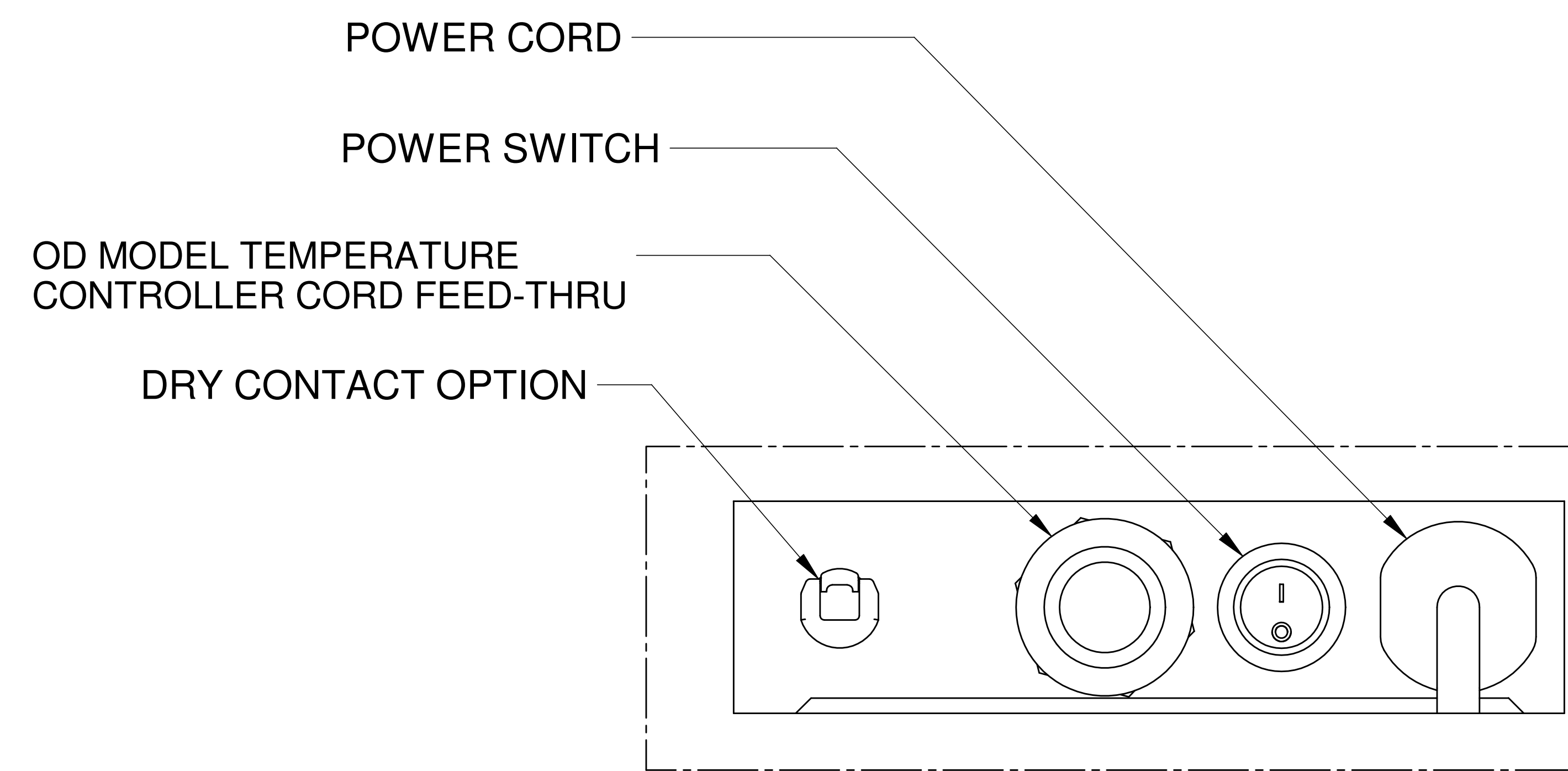

DETAIL A

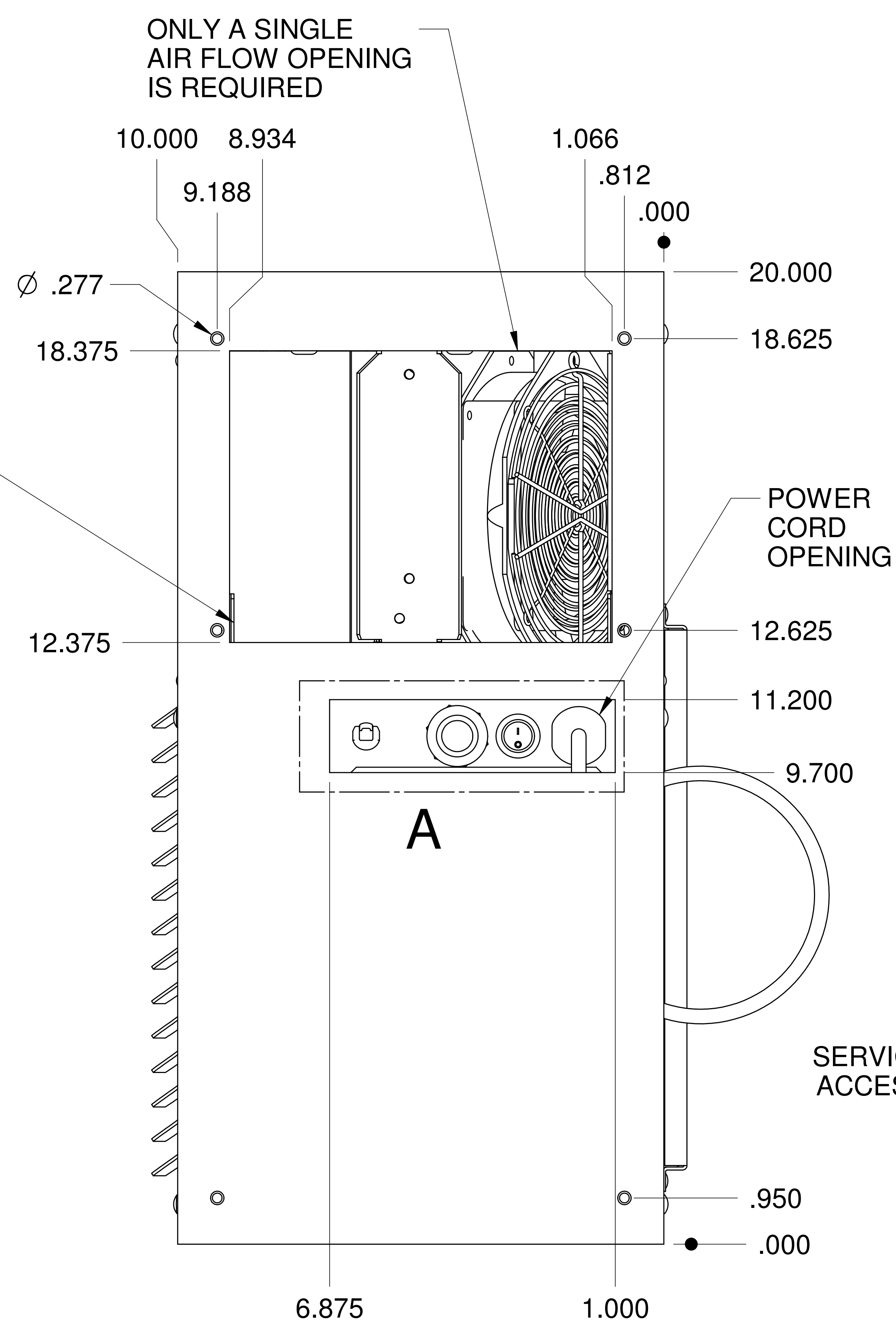

CUTOUT DIMENSIONS AS VIEWED FROM INSIDE ENCLOSURE

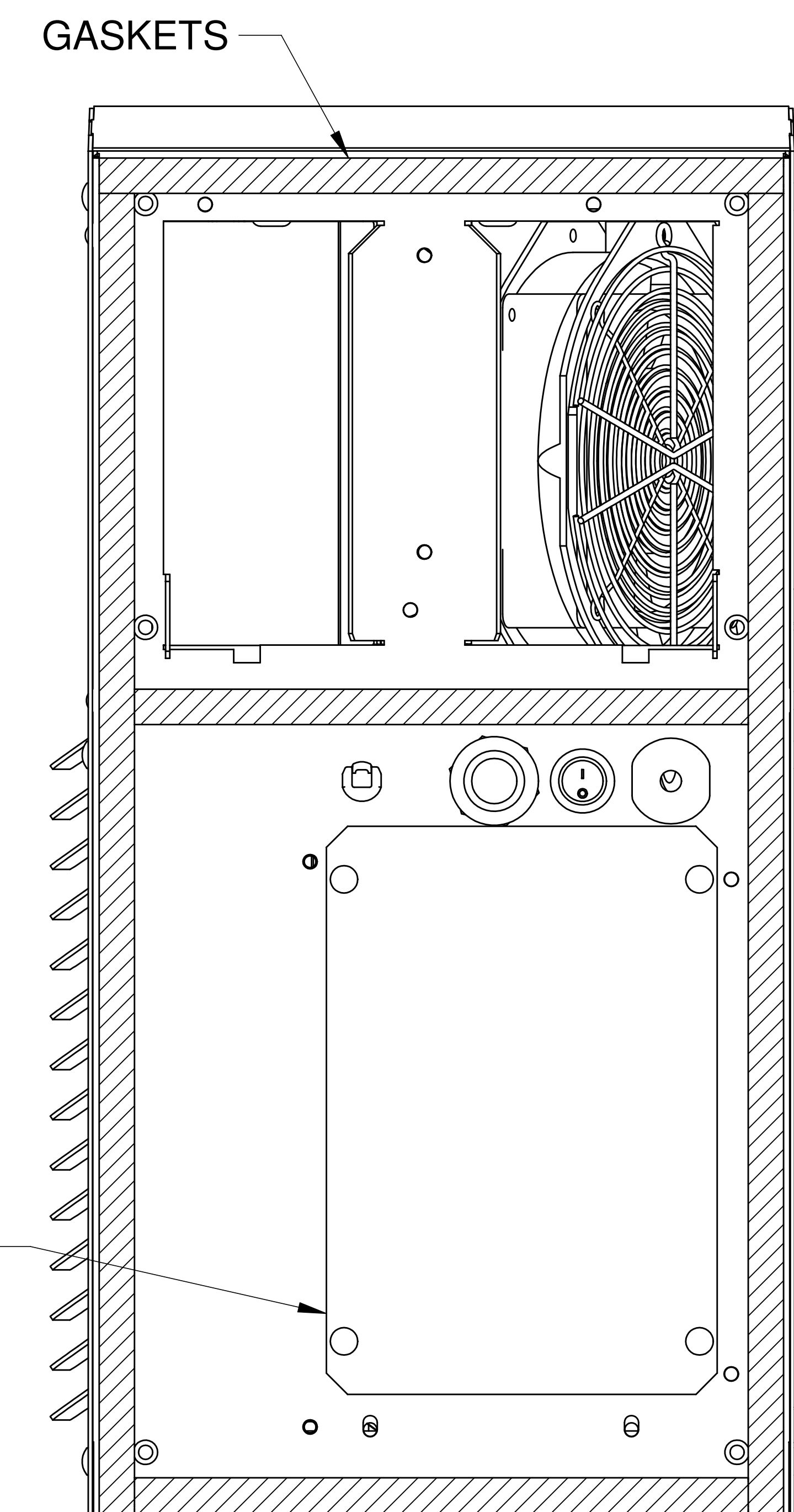

TITLE		
COMPACT SERIES		
CS020		
SIZE	DWG NO	REV
7 1/2" x 4 1/4"		
CS020		
SCALE:	WEIGHT:	SHEET 1 OF 1